

DENTAL UNIT

CLESTA eIII

OPERATING INSTRUCTIONS

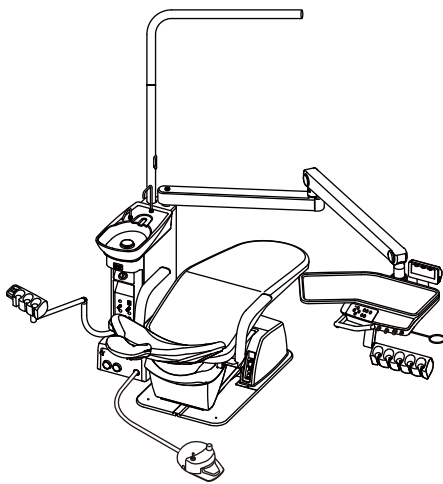

Over the Patient, Holder Type

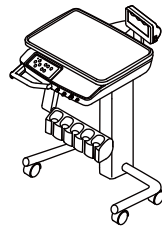

Cart Type

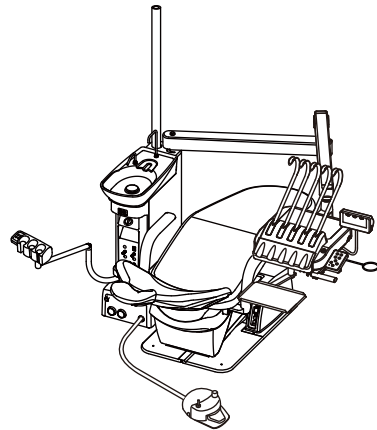

Over the Patient, Continental Type

Thank you for purchasing TAKARA BELMONT product.

- **Please read through this instruction manual carefully before using the product to ensure proper use. Failure to read the instruction manual before use may lead to an accident.**
- **After the installation has been completed, keep this instruction manual near the product for future maintenance. Refer this manual as needed.**
- **If you have any questions about this Manual or this product, please contact us. If manual becomes unreadable or is lost, please request a new manual by contacting your dealer.**
- **Installation should be conducted by authorized personnel only. Follow instructions on installation manual.**

 **Belmont**



TABLE OF CONTENTS

	Page
SAFETY PRECAUTIONS -----	1
OPERATING PRECAUTIONS -----	7
PRACTICE OF FLUSH OUT -----	8
OVERVIEW AND MAJOR COMPONENTS -----	9
DESCRIPTION OF OPERATION	
AND FUNCTIONS OF COMPONENTS -----	11
1. DOCTOR UNIT SECTION -----	11
2. FOOT CONTROLLER -----	18
3. CUSPIDOR UNIT SECTION -----	18
4. UTILITY BOX SECTION -----	22
LOCK FUNCTION -----	22
ADJUSTMENT OF PARTS -----	23
1. DOCTOR UNIT SECTION -----	23
2. CUSPIDOR UNIT SECTION -----	23
3. UTILITY BOX SECTION -----	24
CARE AND MAINTENANCE -----	25
1. DOCTOR UNIT SECTION -----	25
2. CUSPIDOR UNIT SECTION -----	27
3. UTILITY BOX SECTION -----	31
4. PRODUCT EXTERIOR -----	31
SPECIFICATIONS -----	32
ELECTROMAGNETIC COMPATIBILITY(EMC) -----	33
HANDPIECES THAT CAN BE USED WITH THIS PRODUCT -----	35
CHAIR THAT CAN BE USED WITH THIS PRODUCT -----	35
DENTAL LIGHT THAT CAN BE USED WITH THIS PRODUCT -----	35
BEFORE ASKING FOR REPAIRS -----	36
STORAGE METHOD -----	37
MAINTENANCE AND INSPECTION -----	38
ACCESSORIES -----	41
DETACHABLE PARTS -----	42

Intended Use of the Product

This product is an active therapeutic device intended for the exclusive use for diagnoses, treatments and relative procedures of dentistry.

The product must be operated or handled by the qualified dentists or by dental staffs under the supervision of the dentist.

Such dentists or dental staffs should instruct and/or assist the patients to approach to and leave from the product.

Patients should not be allowed to operate or handle the product unless he/she is so instructed.

The product is supplied together with the handpieces like electric micromotor, air turbine and/or motor, scaler and so on.

In addition, it is the device which combines with dental chair and dental light.

Compliance with Directives

CLESTA eIII Compliance with the following directives, Medical Device Directive 93/42/EEC, RoHS Directive 2011/65/EU.

Handpieces that can be used with this product

Use the Handpieces described on page 35.

Chair that can be used with this product

Use the Chair described on page 35.

Dental Light that can be used with this product

Use the Dental Light described on page 35.

Important Notes

In case of the troubles, please contact Takara Belmont offices or your dealers.

Do not disassemble or attempt to repair.

Disassembly, repair or fuse replacement should only be done by a qualified repair technician.

Attempts at disassembly, repair or modifications may lead to abnormal operation and accidents.

In case of disposal of equipment

When disposing the unit, appropriately dispose complying with all current applicable regulations and local codes.



























In EU area, EU directive on waste electrical and electronic equipment (WEEE) is applied on this product. In this directive, environment conscious recycling/abandonment is obligated.

Disposal of residue material

Please request a special contractor when you dispose amalgam.

SYMBOLS



In this manual, on the labels on the control panel of CLESTA eIII, following symbols are used. Confirm the meaning of each symbol.

	Protective earth (ground)		ON (power)		OFF (power)		Alternating current
LP	Chair last position	0	Chair auto return	1	Chair preset1	2	Chair preset2
	Chair manual control		To raise the chair		To Recline the backrest		To lower the chair
	To raise the backrest		Bowl flush		Cupfiller		Syringe
	Dental light select switch		Service outlet (water)		Service outlet (air)		Water heater
W	Water	A	Air		Scaler power control		Micromotor limit rotation speed control
	Micromotor Forward/Reverse select	 *1	Refer to operating instructions		General warning sign		Caution
IPX 1	Classification of foot controller		Type B Applied Parts	REF	Reference number	SN	Serial number
	Manufacturer		Date of manufacture	CE 0197	Comply with MDD,93/42/EEC	EC REP	Authorized representative in the European community
	Separate collection for electrical and electronic equipment		Autoclave Symbol This symbol on component means that the component can be sterilised with an autoclave at 135°C max.				

*1 : The color of black part is blue in the actual label.

SAFETY PRECAUTIONS

- Before use, read the “Safety precautions” carefully to ensure proper use.
- The following information is designed to ensure safe use of this product and to prevent injury and damage to you and others. The precautions contained here are classified depending on the severity and degree of imminence of possible injury or damage resulting from improper use. Be sure to follow all the information, which is important for safety.

Classification of precautions	Severity and degree of imminence of possible injury or damage
 WARNING	This symbol indicates that “ignorance of these precautions may lead to severe injury or even death as a result of improper use.”
 CAUTION	This symbol indicates that “ignorance of these precautions may lead to mild or moderate physical injury or damage to property as a result of improper use.”
NOTICE	This symbol indicates that “it is recommended to follow these precautions for safety.”

 **WARNING**

- 1. Be sure to turn off breakers for equipment in the clinic when this product will not be used for a long period of time**

Be sure to turn off breakers for equipment in the clinic when this product will not be used for a long period of time (following the completion of work, during the suspension of business, etc.). Insulation degradation may cause electrical fire.
- 2. Be sure to turn off the main switch upon completion of work or during work breaks**

Be sure to turn off the main switch upon completion of work or during work breaks. This prevents incorrect operation due to accidental contact and associated hazards.
- 3. Do not sit on other than seat**

When the backrest is at the forward position, do not sit on or place an undue load on the headrest or legrest of dental chair. This could cause the unit to topple or could damage the unit.
- 4. Do not place an undue load on the arm**

Do not get on or place an undue load on the arm of this unit or dental chair armrest. This could cause the unit to topple or other accidents.
- 5. Be sure to establish a grounding connection**

Be sure to establish a proper grounding connection. (Refer to a vendor for grounding connection.) Failure or electric leakage may lead to electric shock.
- 6. Never disassemble, repair or modify this product**

Individuals other than certified repair technicians should not disassemble or attempt to repair and modify this product. This could lead to an accident, failure, electric shock or fire.
- 7. Use with caution in the presence of electromagnetic interference waves**

Do not place this product around equipment generating electromagnetic waves (including communications equipment, elevators, etc.) as incorrect operation of this product may occur in the presence of electromagnetic interference waves. Do not use equipment generating electromagnetic waves, such as mobile phones, around this product.
- 8. Be sure to turn off the main switch when electrocautery is in use**

Be sure to turn off the main switch when electrocautery is in use, because noise may cause incorrect operation of this product.

SAFETY PRECAUTIONS



9. Ensure the maintenance of this product

- Failure to maintain this product may lead to physical injury or property damage.
- Refer to the section of maintenance.

10. Do not place objects weighing 2 kg or more on the Doctor's table

Do not place objects weighing two kilograms or more on the Doctor's table. This could cause damage to the Doctor's table, defective function or accidents.

11. Do not place objects weighing 1.5 kg or more on the sub tray (Continental Type)

Do not place objects weighing 1.5 kilograms or more on the sub tray. This could cause damage to the sub tray, defective function or accidents.

12. Do not place objects weighing 1.5 kg or more on the Assistant sub tray

Do not place objects weighing 1.5 kilograms or more on the Assistant sub tray. This could cause damage to the Assistant sub tray, defective function or accidents.

13. Be sure to use the mirror cover

- Be sure to use the mirror cover of the dental light when the light is turned on. Direct contact with lamps may cause burns.
- See the Instruction Manual of the dental light for further information.

14. Be sure to turn off the power when replacing lamps

- Be sure to turn off the power when replacing the dental light. This could result in electric shock.
- Use only dedicated halogen lamps.
- Immediately after a halogen lamp has burnt out, the lamp and the lamp holder are still hot. Replace the lamp after they cool down.
- Do not touch halogen lamps with bare hands.
- See the Instruction Manual of the dental light for further information.

15. Immediately wipe off any water spills or leakage on the floor

Immediately wipe off any water spills or leakage on the floor. This could cause damage to the product, decreased strength of the floor may lead to physical injury including fall, or property damage.

16. Use with caution on patients with a cardiac pacemaker

Use this product with extreme caution on patients with a cardiac pacemaker. In the case of any abnormalities in patients during use, immediately turn off this product and discontinue use.

17. Prohibition of maintenance

During operation, repair and maintenance are prohibited.

18. Prohibition of using this equipment adjacent to or stacked with other electronic equipment

Use of this equipment adjacent to or stacked with other equipment should be avoided because it could result in improper operation. If such use is necessary, this equipment and the other equipment should be observed to verify that they are operating normally.

19. Prohibition of placing portable RF communications equipment adjacent to this product

Portable RF communications equipment (including peripherals such as antenna cables and external antennas) should be used no closer than 30 cm (12 inches) to any part of the CLESTA eIII, including cables specified by the manufacturer. Otherwise, degradation of the performance of this equipment could result.

SAFETY PRECAUTIONS



1. Only experienced personnel should use this product

Only dentists or other dental professionals should use this product.

2. Confirm safety before use

Before use, confirm that the parts are correctly and safely operating and that there are no obstacles around this product.

3. Pay attention to patients and children

Keep your eyes on patients (especially, children) so that mischief or inadvertent operation of equipment will not lead to unexpected accidents.

4. Discontinue use if you feel that “something is wrong”

Always be careful to inspect this product for looseness, rattling, tilting, wobbling, sounds, temperature, odors, etc. Immediately discontinue use at the first feeling that “something is wrong.”

5. Keep your eyes on the patient during operation.

- Confirm that the patient is seated in the proper position. Keep your eyes on the patient during the operation.
- Pay special attention to surroundings at automatic operation of the dental treatment table. Damage to the backrest, stool or Doctor's table may occur.

6. Pay attention during movement of the Doctor's table

- Pay attention to surroundings when you move the Doctor's table. Injury by the tips of handpieces, etc., may occur.
- Be sure to move the Doctor's table by holding the handle of the unit.
- Be sure to move up & down the Doctor's table by releasing the balance arm brake of the unit in the case of over the patient type. If the brake is not released, the table may drop resulting in defective function.
- Be careful not to run onto the cart hose with a caster when you move the cart type table. This could cause the unit to topple. Also, be careful not to hit a foot controller.
- Be sure that the sub tray and the subtray arm does not hit the patient when the continental holder type is placed above the patient's chest.

7. Do not pull the handpiece hose excessively (Continental Type)

Do not pull the handpiece hose excessively. This could cause damage to the rod.

8. Cautions at adjusting the height of the cart-type instrument table (Cart type only)

After adjusting the height, be sure to tighten the lock knob. If not, the table may drop, resulting in an accident.

9. Pay attention when you move a stool

Pay attention to surroundings when you move a stool. Not to hit the Doctor's table or a Foot controller. This could cause malfunction or damage to the unit.

10. Do not smack or rub this product

Do not smack or rub this product forcefully. This could cause damage to covers or defective function.

11. Immediately wipe off drug solution when it comes into contact with this unit

Should drug solution or water comes into contact with this unit, immediately wipe it off with a dry soft towel, etc. This could result in defective function or electric leakage as well as spotting or rusting.

12. Turn off the main switch upon completion of work

Be sure to turn off the main switch at the end of each work day to prevent from water leakage, electrical accident.

13. Be sure to operate switches with your hands

Be sure to operate switches with your hands, except the foot controller, which is operated with your foot. Operation with body parts other than hands may cause damage or incorrect operation.

14. Pay attention during the headrest operation

Do not allow hands, fingers, or hair to become entangled in the moving parts of the headrest during operation.

15. Be careful not to heat an empty water heater

Exercise caution as heating of an empty water heater may result in burning of the heater, leading to fire.

SAFETY PRECAUTIONS



16. Precautions for cleaning

- Never use sandpaper, metal scrub brushes and abrasive cleaning agents to clean the unit.
- Do not use strongly acidic cleaning agents or alkaline pipe cleaning agents to avoid corrosion of metals, etc.

17. Precautions for sterilization

Do not sterilize besides the procedures that we provide. This could cause damage to the unit.

18. Set the pressure of the water tank at 200 kPa or less

Adjust the air supply pressure for the water tank to 200 kPa or less. An excessively high pressure may cause damage to the water tank.

19. Do not use water other than purified water, distilled water or pure water for the water tank

- The water tank is intended only for use with purified water, distilled water and pure water.
- Do not use mouthwash or electrolyzed water, such as ConCool or povidone iodine, as they may cause clogged tubing or affect internal valves and equipment.

20. Read the documents accompanying the various pieces of equipment

Before use, be sure to carefully read the package inserts and Instruction Manuals accompanying the various pieces of equipment (including optional articles) to ensure proper use.

21. Combination with accessories or other devices

Use only our qualified accessories, other devices or equipment for this product to ensure the safety of product.

22. Pay attention to allergic reaction of a patient

While a vaccume tip is placed in a patient mouse, pay attention to allergic reaction.
If allergic reaction start to happen, immediately stop the usage of a vaccume tip.

23. When you are working with a handpiece, do not pick up another handpiece

When you are working with a handpiece, do not pick up another handpiece. Another handpiece may rotate and cause an injury. Do not pick up two handpieces at the same time.

24. Clean and sterilize the vacuum tip before use

The vacuum tip, which contacts oral tissues, is provided without sterilization.
Cleaning and sterilization is necessary before use.
For the method of cleaning and sterilization, see "Care and Maintenance" on page 28 to 30.

25. Be careful not to drop the handpiece

Be careful not to drop the handpiece. Otherwise, it may break or the handpiece may deform.

SAFETY PRECAUTIONS

NOTICE

1. Troubleshooting and contact information

In the case of any problems, discontinue use, turn off the main switch and contact the dealer or our company.

2. Check operation of the compressor

With no air supplied, this product does not operate even after turning on the main switch. Turn on the power of the compressor before operating this product.

3. Procedural water for dental treatment

For procedural water, follow the requirements of local regulations.

Commercial distilled water is recommended in case the quality of tap water may not be safe.

The water unit is intended for use with tap water. Caution should be exercised as the use of water other than tap water (water through a sterilizer or water systems, etc.) may result in failure of equipment.

4. Use the turbine with a water check valve

Use the turbine with a water check valve. Contact the dealer or our company when a turbine without a water check valve will be used.

5. Handling of equipment in the case of a power failure

Put the handpiece in the holder and turn off the main switch if equipment stops working during use due to a power failure or other reasons.

6. Be careful not to drop the handpiece

Be careful not to drop the handpiece. Otherwise, it may break or the handpiece may deform.

SAFETY PRECAUTIONS

■ Caution Points During Operation of the Product

Description of Symbol Marks

- ➔ : Caution areas such as moving parts, rotating parts and detachable parts to which caution should be paid.
- : Caution areas that are provided with an emergency stop mechanism.

Over the Patient, Holder Type

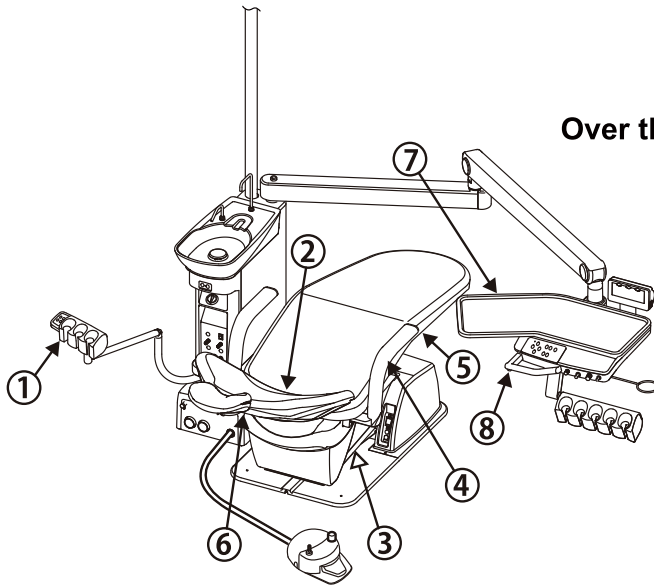

Over the Patient, Continental Type

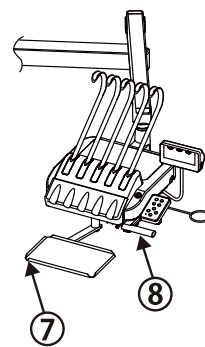

Cart Type

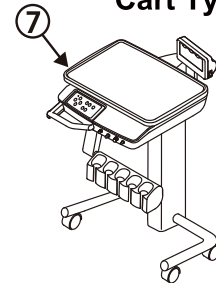

① Be aware of contact with the assistant's instrument holder.

Ensure that the upper body of the patient does not go beyond the armrest into the cuspidor unit.

② Take care not to be trapped by moving parts of the backrest.

Do not put hands or feet into the gap between the backrest and the seat.

③ Take care not to be trapped between the sub link cover and the base plate

Do not allow feet or obstruct between the sub link cover and the base plate.

④ Take care not to be trapped by the armrest.

Do not operate the chair with the right armrest swung out 90 degrees.

⑤ Take care not to be trapped by the lower part of the seat.

Do not put hands or feet into the gap in the lower part of the seat.

⑥ Take care not to be trapped by moving parts of the headrest.

Do not allow hands, fingers, or hair to become entangled in the moving parts of the headrest.

⑦ Be aware of interference between the chair and the table.

Do not move the table under the moving parts of the chair.

⑧ Pay attention while moving the Doctor's table up & down

Do not move up & down the Doctor's table by without releasing the balance arm brake.

OPERATING PRECAUTIONS

■ Please observe following cautions to avoid the damage.

CAUTION

1. Do not place anything hot on the unit

Do not place anything hot on the unit. This could cause deformation or discoloration.

2. Precautions for cleaning of the spittoon

The spittoon is made of ceramic. Never use sandpaper, metal scrub brushes or abrasive cleaning agents to clean the spittoon.

3. Precautions for cleaning the resin cover

For cleaning, do not use cleaning agents containing solvent or abrasives, thinners or oil-based alcohol (butanol and isopropyl alcohol), which may cause cracks.

4. Precautions for cleaning the operation panel (Membrane switches)

Penetration of droplets of sanitizing spray into the back of the operation panel may be associated with switch failure.

Use a paper towel soaked with sanitizing solution to clean the surface of the operation panel.

5. Precautions for cleaning

- Never use sandpaper, metal scrub brushes and abrasive cleaning agents to clean the unit.
- Do not use strongly acidic cleaning agents or alkaline pipe cleaning agents to avoid corrosion of metals, etc.

6. Insert the nozzle straight into spittoon

- Be sure to insert the cupfiller nozzle and bowl flush nozzle straight into each hole on the spittoon bowl after cleaning. Damage to the o-ring may lead to water leakage.

7. Move the table to highest position upon completion of work (Over the patient type)

When air exhausts from balance arm brake while no object is placed on the table, the doctor table may automatically raise to the highest position. Move the table to the highest position upon completion of work.

8. Use dental paper cups (Option sensor cupfiller)

Use dental paper cups for sensor cupfiller (option). If the cup is another material grade (such as stainless steel and plastics) or if the paper cup is of dark color or pattern, which the sensing cup filling sensor may not respond.

PRACTICE OF FLUSH OUT

PRECAUTIONS FOR WATER QUALITY

CAUTION

Practice the flush out of water retained in the unit at the beginning of each work day to maintain the quality of dental treatment water and ensure a steady supply of water to handpieces.

- After this unit has not been used for a long period of time (at the beginning of the week, in the morning, etc.), water retained in the hose inside the unit or water heater will create an environment where unwanted bacteria are likely to grow. In order to ensure safe treatment and untroubled operation of handpieces, practice the flush out of the unit water line at the beginning of each work day.
- It is recommended that flush out of water inside the unit and hose of handpieces should be performed with fresh water at the end of morning office hours and at the end of each work day to inhibit the growth of unwanted bacteria.

Standard time required for flush out of the unit water line

<ul style="list-style-type: none"> ● Handpiece line Turbine Air Motor Scaler Syringe (Both Doctor' s and Assistant's) 	<p>Approximately 40 seconds per turbine, air motor, scaler and syringe (approximately 40 seconds when flush out of all of them is performed at the same time.)</p> <p> CAUTION Perform flush out of the scaler with it attached to the main unit. Otherwise, a malfunction may be caused.</p>
<ul style="list-style-type: none"> ● Cuspidor line Cup filler (water heater) Bowl flush 	<p>Approximately five minutes for water changing in the cup filler line.</p>

PROCEDURE OF FLUSH OUT

<ul style="list-style-type: none"> ● Handpiece line Pick up handpieces from the holder one at a time, leave the turbine untouched and remove the bar from the motor and hold the motor over the spittoon bowl. (When the flush out function is active, pick up all handpieces in clusters and hold them over the spittoon bowl.) 	<ul style="list-style-type: none"> ● Without Flushout Function Press the foot controller to flush out of the handpiece water. ● With Flushout Function Pick up the handpieces then turn on the flush out switch to flush out the handpiece water.
<ul style="list-style-type: none"> ● Cuspidor line Cupfiller (water heater) Bowl flush 	<ul style="list-style-type: none"> ● The water filled to the cup, then drain the water of the cup to flushing out the cupfiller water. Repeat it 7~8 times.

OVERVIEW AND MAJOR COMPONENTS

Over the Patient, Holder Type

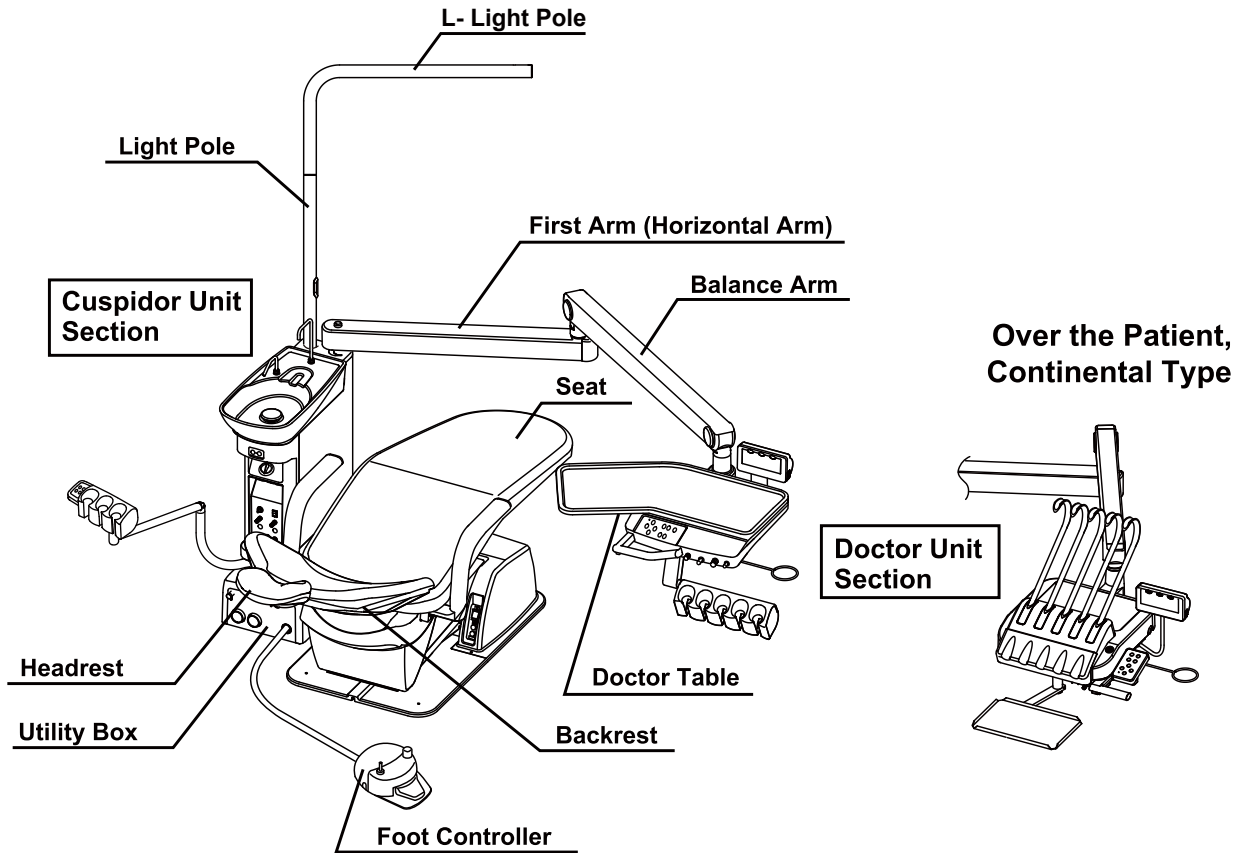

! WARNING

Do not get on or place an undue load on the arm of this unit.

Cart Type

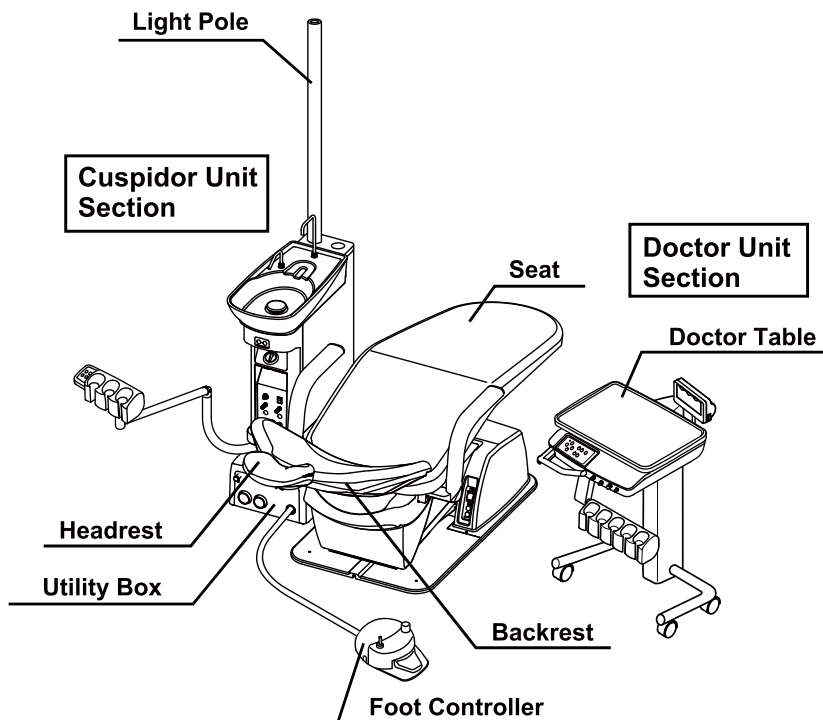

OVERVIEW AND MAJOR COMPONENTS

Doctor Unit Section

Over the Patient, Holder Type

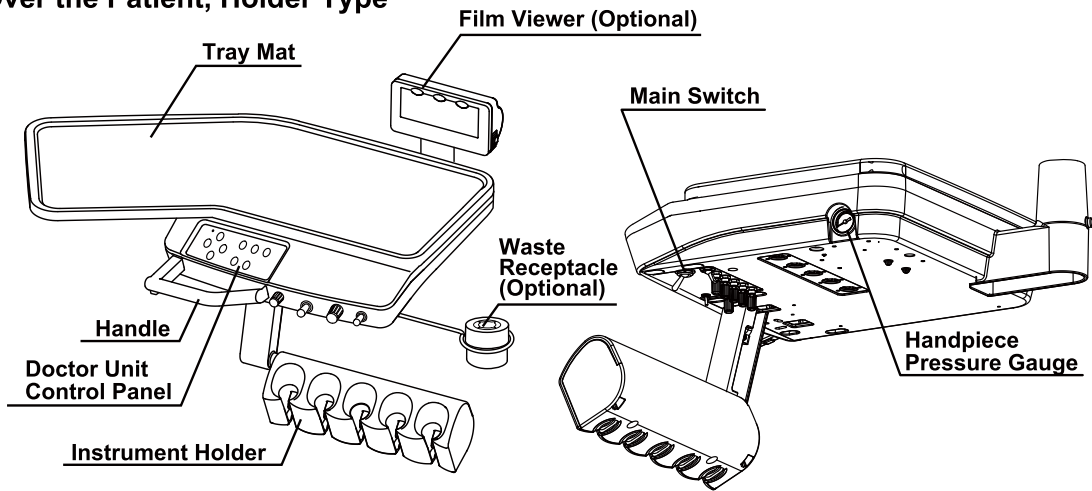

Over the Patient, Continental Type

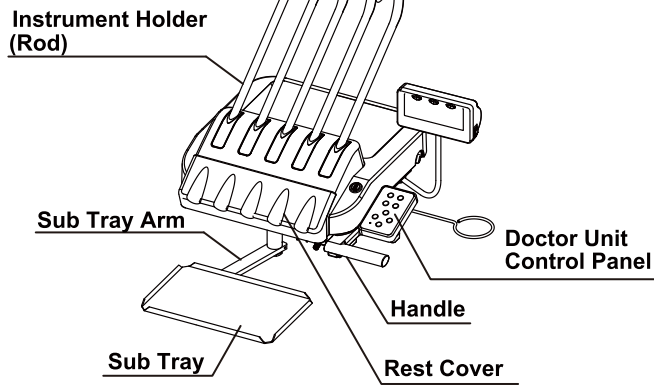

Cart Type

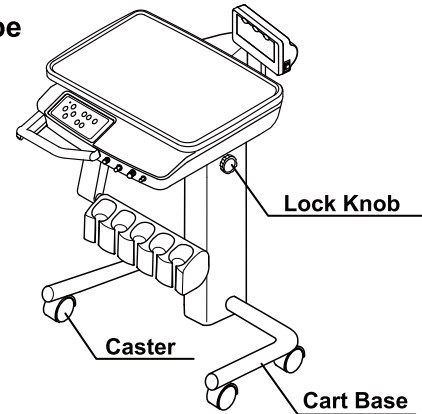

Cuspidor Unit Section

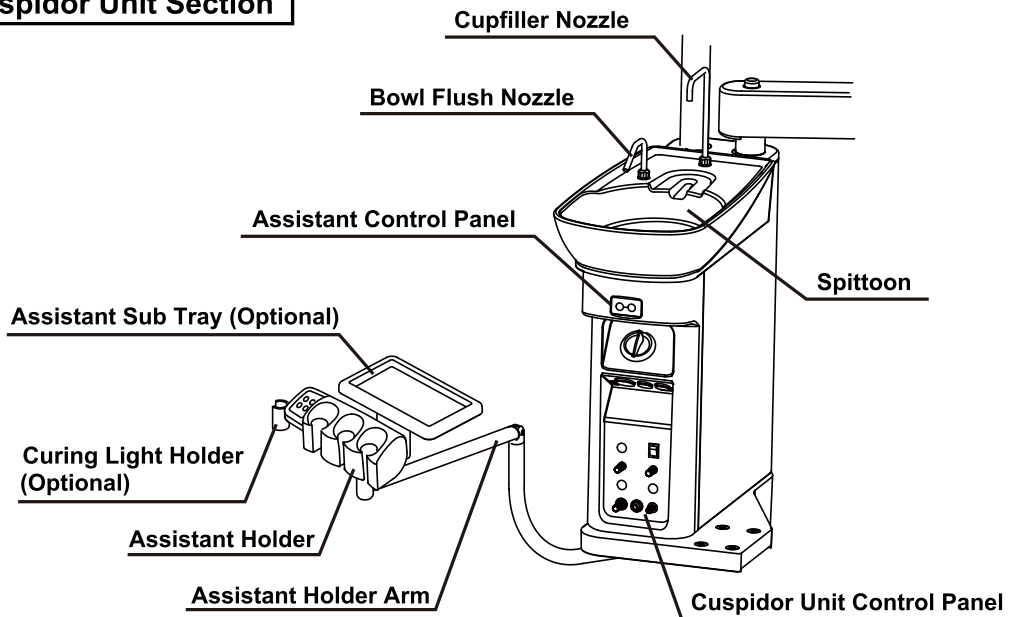

DESCRIPTION OF OPERATION AND FUNCTIONS OF COMPONENTS

1 Doctor Unit Section (Holder Type)

■ Main Switch

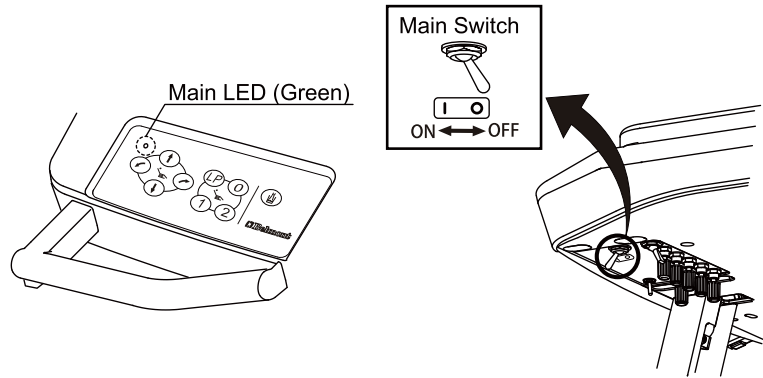

- Turn on the main switch to forward (I marked) as viewed the doctor table from the front, the MAIN LED on the doctor membrane switch panel lights up in green. This state permits motion of the unit and chair.
- * With no air supplied, this product does not operate even after turning on the main switch. Turn on the power of the compressor before operating this product.

■ Handpiece

- The handpiece is actuated by picking it up from the handpiece holder and operating the foot controller. Operation of the each handpieces, please refer to the manufacturer's instruction manual attached to the individual equipment. Use the Handpieces described on page 35.

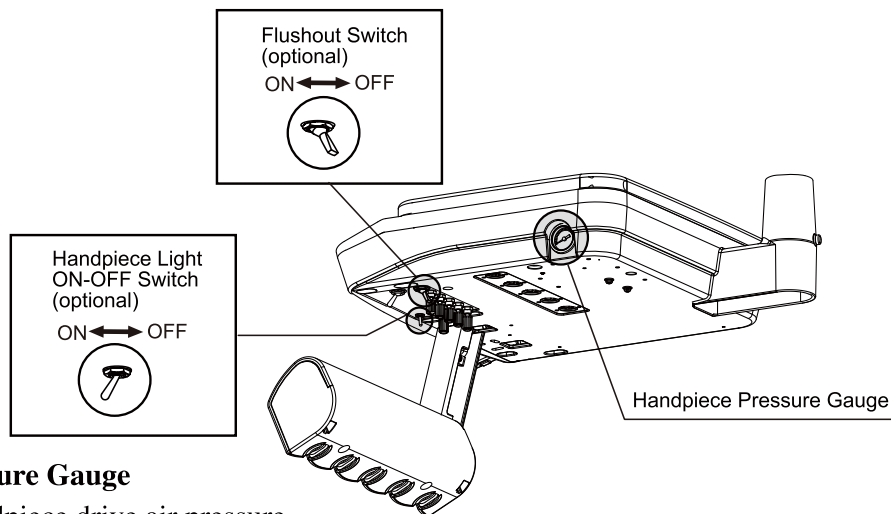

■ Handpiece Pressure Gauge

- Displays the handpiece drive air pressure.

■ Flushout Switch (Optional)

- Pick up the handpiece from handpiece holder and turn on the flushout switch to forward as viewed the doctor table from the front, then the flushout of handpiece water line begins.
- During flushout, turn off the flushout switch will cancel flushout immediately.

■ Handpiece Light ON-OFF Switch (Optional)

- Switching between on and off of the handpiece light occurs each time when this switch is changed to forward (on) and backward (off) as viewed the doctor table from the front.

⚠ CAUTION

Be sure to operate switches with your hands. If operate with other than hands may cause damage or incorrect operation.

DESCRIPTION OF OPERATION AND FUNCTIONS OF COMPONENTS

1 Doctor Unit Section (Continental Type)

■ Main Switch

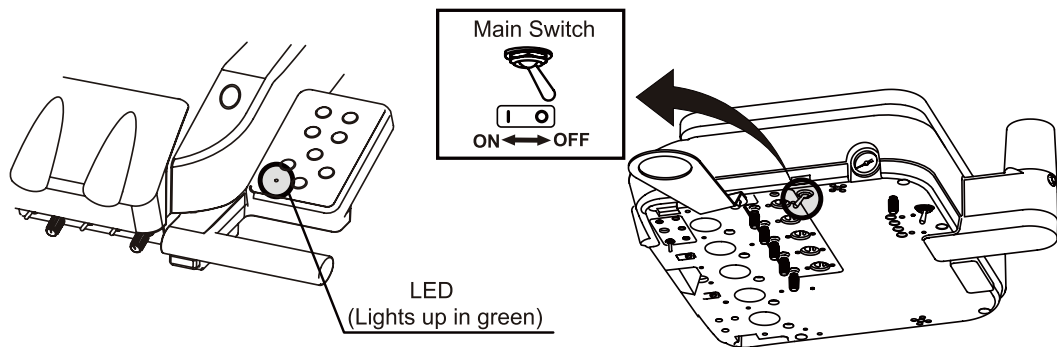

- Turn on the main switch to forward (I marked) as viewed the doctor table from the front, the MAIN LED on the doctor membrane switch panel lights up in green. This state permits motion of the unit and chair.
- * With no air supplied, this product does not operate even after turning on the main switch. Turn on the power of the compressor before operating this product.

■ Handpiece

- The handpiece is actuated by picking it up from the handpiece holder and operating the foot controller. Operation of the each handpieces, please refer to the manufacturer's instruction manual attached to the individual equipment. Use the Handpieces described on page 35.

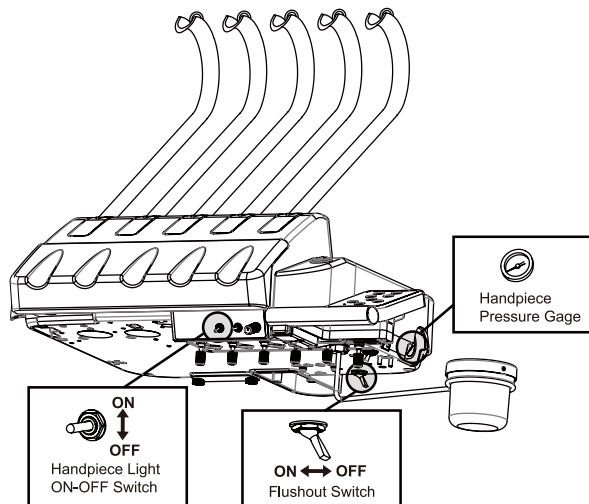

■ Handpiece Pressure Gauge

- Displays the handpiece drive air pressure.

■ Flushout Switch (Optional)

- Pick up the handpiece from handpiece holder and turn on the flushout switch to left as viewed the doctor table from the front, then the flushout of handpiece water line begins.
- During flushout, turn off the flushout switch will cancel flushout immediately.

■ Handpiece Light ON-OFF Switch (Optional)

- Switching between on and off of the handpiece light occurs each time when this switch is changed to forward (on) and backward (off) as viewed from the front.

⚠ CAUTION

Be sure to operate switches with your hands. If operate with other than hands may cause damage or incorrect operation.

DESCRIPTION OF OPERATION AND FUNCTIONS OF COMPONENTS

1 Doctor Unit Section

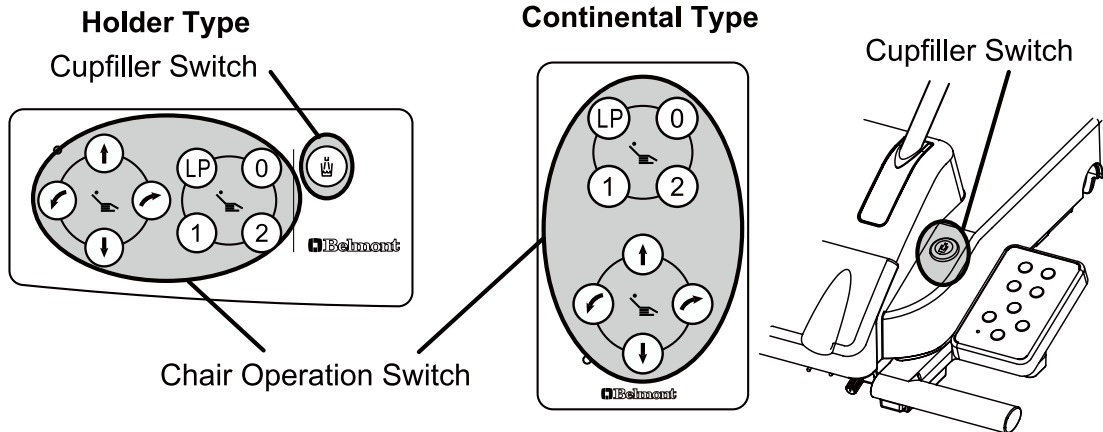

■ Doctor Unit Control Panel (Chair Operation Switch) - Manual Switch -

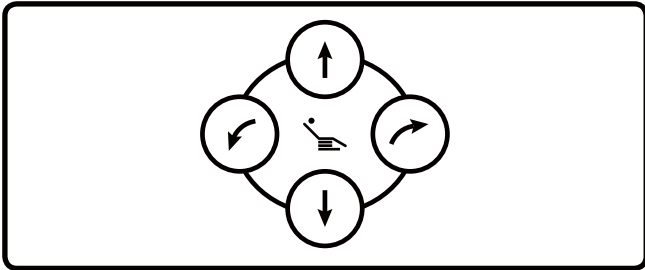

- Switches provide manual operation for up/down and backrest reclining/raising of the chair.
- Press will move the chair up.
- Press will move the chair down
- Press will recline the backrest.
- Press will raise the backrest.

■ Doctor Unit Control Panel (Chair Operation Switch) - Automatic Switch -

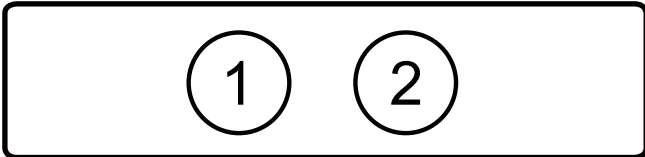

Chair Preset Switch

- Set the chair height and backrest angle in desired position(s), and actuate the chair by either one of these switches. Press any switches(chair/unit) for stopping the automatic movement.

Set the treatment position by chair manual switch

Keep pressing preset switch to be set for about 5 seconds

This block illustrates the procedure for setting a treatment position. It starts with the manual chair operation switch, followed by a large downward arrow indicating the next step. Below the arrow, it instructs the user to 'Keep pressing preset switch to be set for about 5 seconds', accompanied by a diagram of the two preset switches labeled '1' and '2'.

【Preset position setup procedures】

1. Move the chair to the treatment position using manual switches.
2. Upon deciding of the desired treatment position, keep pressing preset switch < ① >, or < ② > to be set for about 5 seconds. The buzzer sounds from the chair, and setup has been completed.
3. To change the set position, perform the procedures steps 1 and 2 above.

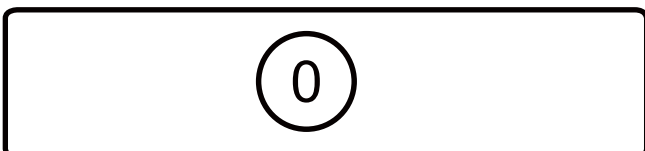

Chair Auto Return Switch

- When this switch is pressed, the chair moves downward to the initial position, and the backrest rises to upright position. Press any switches(chair/unit) for stopping automatic movement.

DESCRIPTION OF OPERATION AND FUNCTIONS OF COMPONENTS

1 Doctor Unit Section

■ Doctor Unit Control Panel (Chair Operation Switch) - Automatic Switch -



Move the chair to rinsing position by chair manual switch

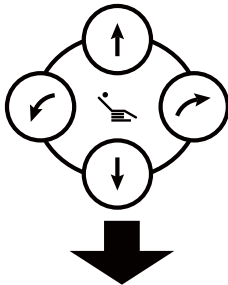

Keep pressing LP for about 5 seconds



Chair Last Position Switch

- When this switch is pressed in the fine-adjusted treatment position, the chair moves to the rinsing position. When the switch is pressed again, the chair returns to the former treatment position.

【Rinsing position setup procedures】

1. Move the chair to the rinsing position using manual switches.
2. Upon deciding the desired rinsing position, keep pressing last position switch <LP> for about 5 seconds. The buzzer sounds from the chair, and setup has been completed.
3. To change the set position, perform the procedures steps 1 and 2 above.

⚠ CAUTION

Confirm that the patient is seated in the proper position before operation of the chair and keep your eyes on the patient during operation. Be careful that the stool will not be caught in the gap between the chair backrest and the headrest when the chair is operated with an auto-switch. Damage to the backrest or stool may occur.

■ Doctor Unit Control Panel (Cupfiller Switch)



Cupfiller Switch

- Water is supplied through the cupfiller nozzle for certain time when this switch is pressed. Simultaneous with start-up of cupfiller motion, water comes out of the bowl flush nozzle and flushes the spittoon.
- * When the cupfiller switch is pressed, water is supplied automatically for certain time irrelevant to the water volume in the cup. Watch the overflow.
- * Do not press the switch while the cup is not in place.

■ Doctor Instrument Holder (Holder Type)

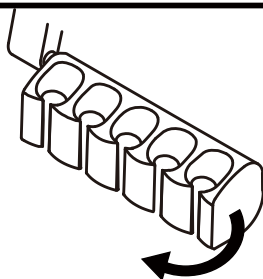

- The instrument holder can be adjusted 23 degrees toward.

DESCRIPTION OF OPERATION AND FUNCTIONS OF COMPONENTS

1 Doctor Unit Section

Balance Arm Air Brake Button (Over the Patient Type)

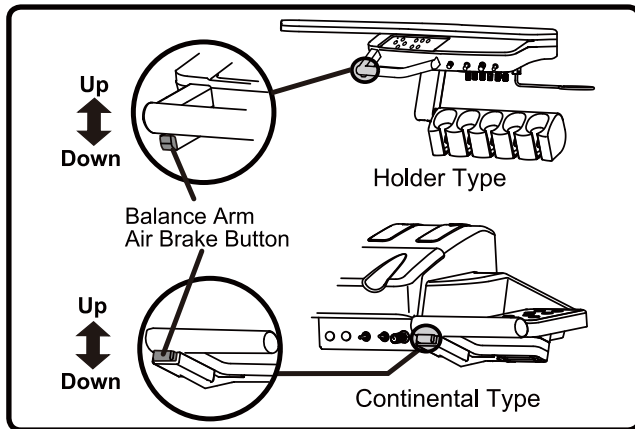

- When the master switch is ON, the balance arm is locked. Grasp the handle and press the air brake button to adjust the table height. Release the air brake button at the desired table position, the balance arm is locked.

⚠ CAUTION

Be sure to move up & down the Doctor's table by releasing the balance arm brake of the unit. If the brake is not released, the table may drop resulting in defective function.

Table Height Adjustment (Cart Type)

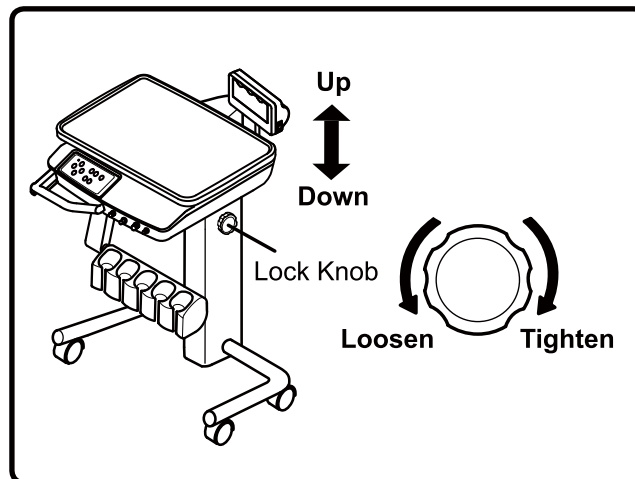

- Loosen the lock knob to raise or lower the table section. Fix the table in place by firmly tightening the lock knob after adjustment.

⚠ CAUTION

- Do not place objects on the table during table height adjustment.
- Be sure to hold the table section before loosen the lock knob.
- Be sure to tighten the lock knob after adjustment.

Dental Size Film Viewer (Optional)

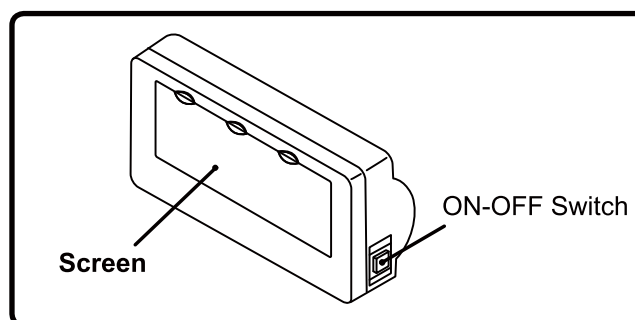

- The screen light is lit when the switch is pressed, and the screen light is off when the switch is pressed again.

NOTICE

Turn off the light when the film viewer is not in use.

Panorama Size Film Viewer (Optional)

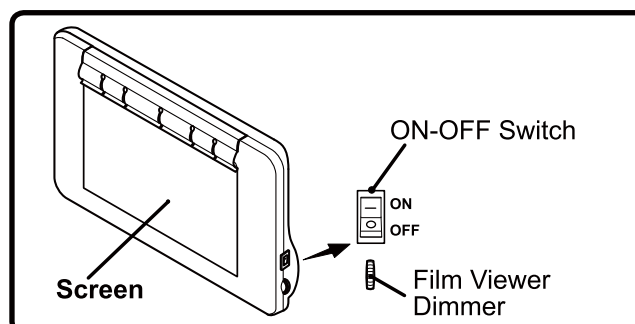

- The screen light is lit when the switch is turned to the side mark with I, and the screen light is off when the switch is turned to the side mark with O.
- The screen brightness increases when the brightness control dial is turned upward, and the screen brightness decreases when the brightness control dial is turned downward.

NOTICE

Turn off the light when the film viewer is not in use.

DESCRIPTION OF OPERATION AND FUNCTIONS OF COMPONENTS

1 Doctor Unit Section

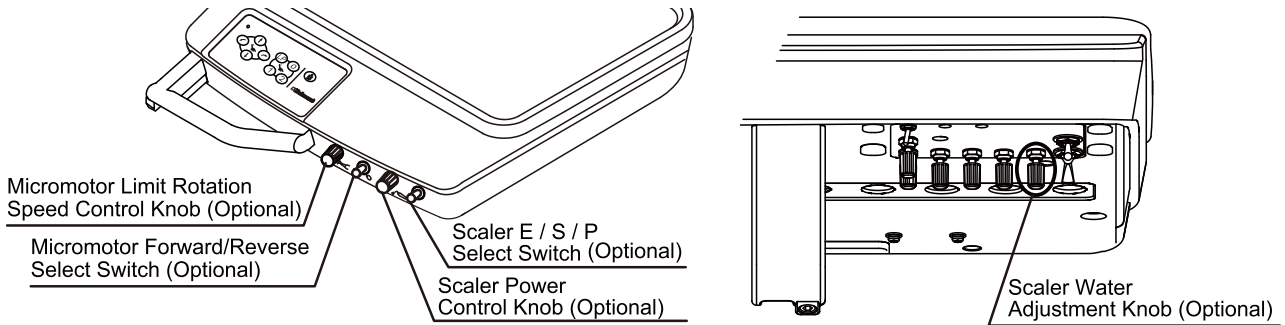

■ Electric Micromotor (Optional)(Holder Type)

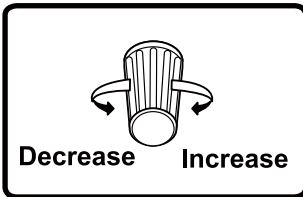

Micromotor Limit Rotation Speed Control Knob (Optional)

- The knob controls the upper limit speeds in micromotor rotation. If the knob is turned right, the upper limit speed increases, and if left, the speed decreases.

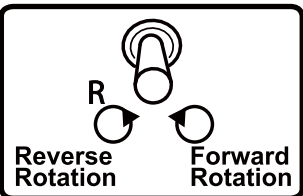
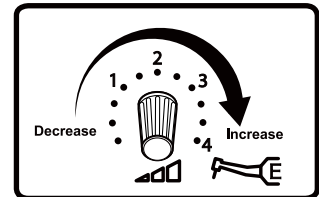

Micromotor Forward/Reverse Select Switch (Optional)

- The switch changes the rotation direction in micromotor. If the switch is turned to the R side, the micromotor rotates reverse direction.

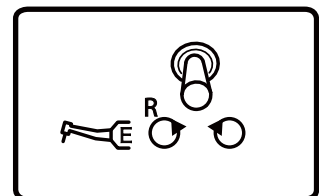

⚠ CAUTION

Do not change the rotation direction while the micromotor is running. It may cause damage to the micromotor.

■ Electric Scaler (Optional) (Holder Type)

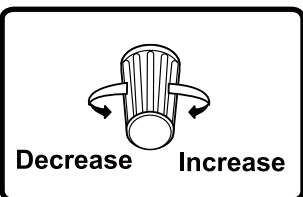

Scaler Power Control Knob (Optional)

- The knob adjusts the output power of the electric scaler. The output power increase when the knob is turned to clockwise, and the output power decrease when the knob is turned to counterclockwise.

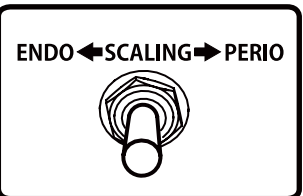
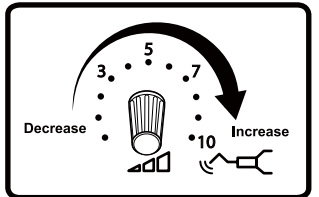

Scaler E / S / P Select Switch (Optional)

- Electric scalers have 3 modes such as E (ENDO), S (SCALING) and P (PERIO) and can be chose a mode by turning the switch. This switch is not used for EMS scaler since these scalers does not have the function to select the mode.

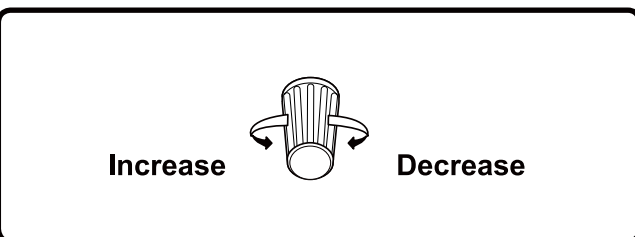
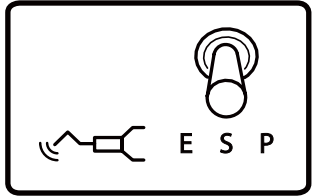

Scaler Water Adjustment Knob (Optional)

- Make adjustment of scaler water by the scaler water adjustment knob. The water flow rate decreases when the knob is turned clockwise, and the water flow rate increases when the knob is turned counterclockwise.

DESCRIPTION OF OPERATION AND FUNCTIONS OF COMPONENTS

1 Doctor Unit Section

■ Electric Scaler (Optional) (Continental Type)

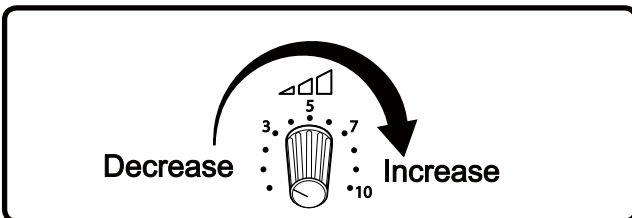
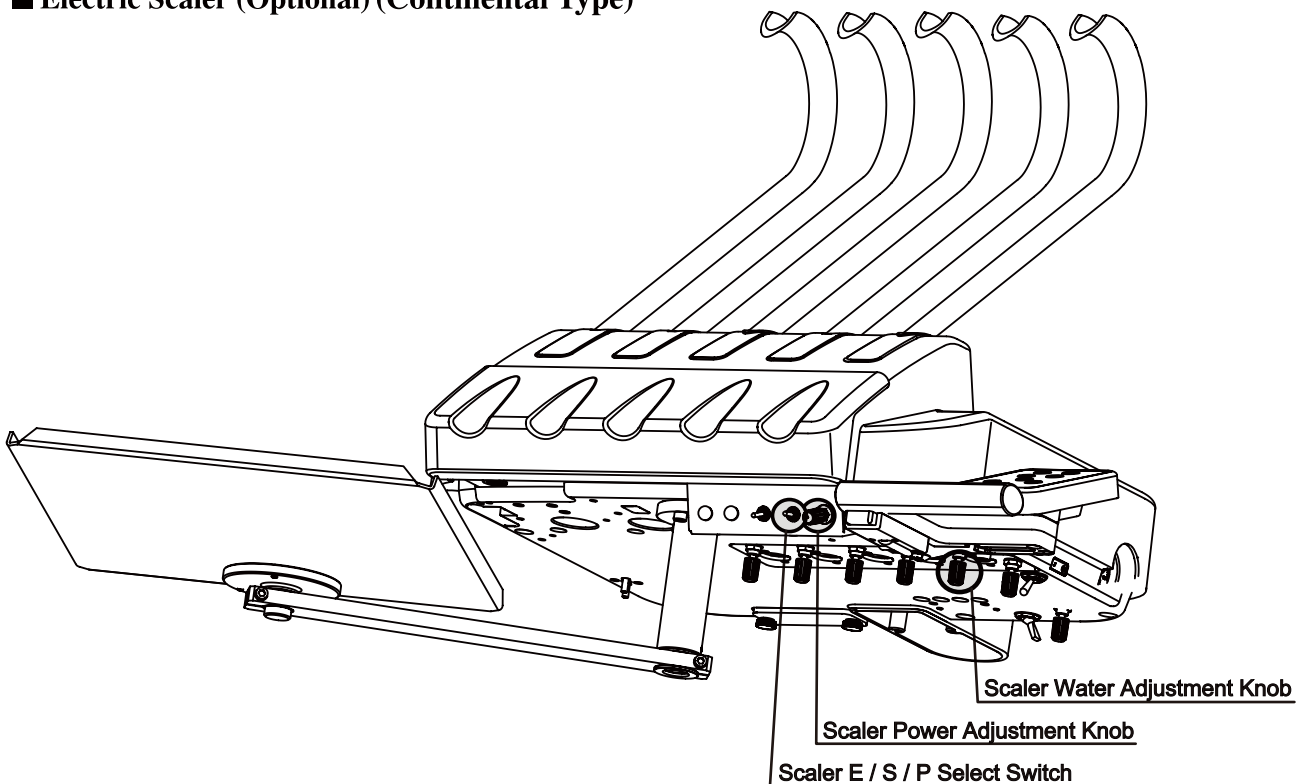

Scaler Power Adjustment Knob (Optional)

- The knob adjusts the output power of the electric scaler. The output power increase when the knob is turned to clockwise, and the output power decrease when the knob is turned to counterclockwise.

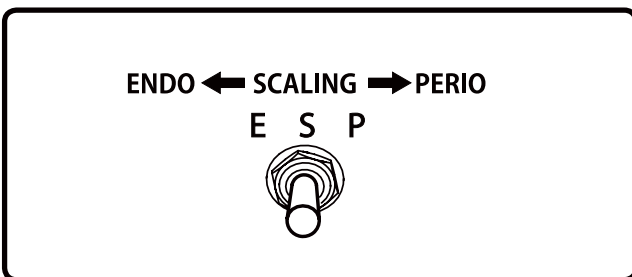

Scaler E / S / P Select Switch (Optional)

- Electric scalers have 3 modes such as E (ENDO), S (SCALING) and P (PERIO) and can be chose a mode by turning the switch. This switch is not used for EMS scaler since this scaler does not have the function to select the mode.

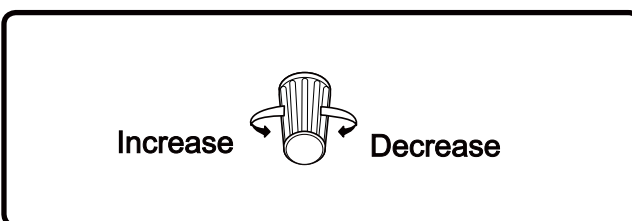

Scaler Water Adjustment Knob (Optional)

- Make adjustment of scaler water by the scaler water adjustment knob. The water flow rate decreases when the knob is turned clockwise, and the water flow rate increases when the knob is turned counterclockwise.

DESCRIPTION OF OPERATION AND FUNCTIONS OF COMPONENTS

2 Foot Controller

■ Type A3 Foot Controller

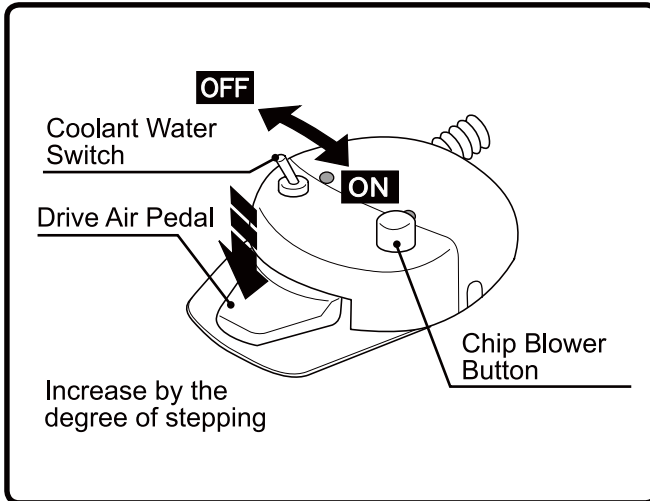

Drive Air Pedal

- The pedal depressing extent can control the turbine and air motor rotation speed and air scaler output.
- The motor rotation is activated when the pedal is depressed. Adjust upper limit speed by turning micromotor limit rotation speed control knob.
- The electric scaler is activated when the pedal is depressed. Adjust the scaler power by turning scaler power adjustment knob.

Coolant Water Switch

- Coolant water switch allows handpiece coolant water to be turned on or off.

Chip Blower Button

- Chip air for blowing off the chips jets out of the handpiece when the chip blow switch is depressed.

■ Foot Switch (Optional)

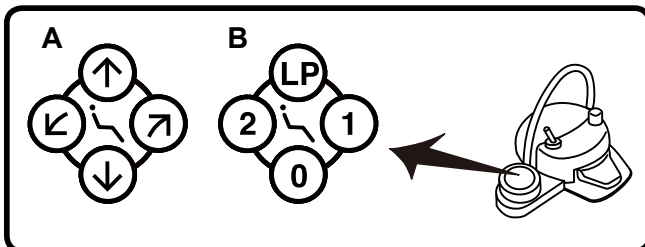

A. Chair Manual Control Switches

B. Chair Auto Mode Switches

Note: Please refer to page 13 to 14.

3 Cuspidor Unit Section

■ Monitor Bracket (Optional)

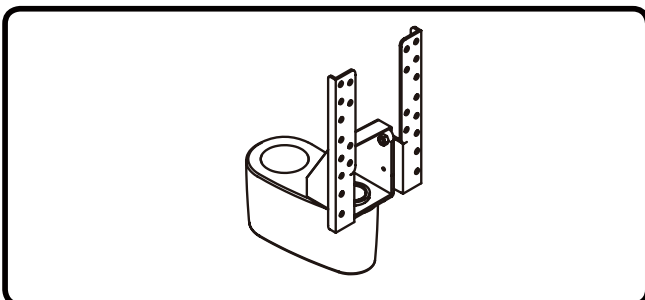

- PC monitor can be mounted on this bracket.

Note: Do not apply an excessive load or shock to the monitor or monitor bracket.

DESCRIPTION OF OPERATION AND FUNCTIONS OF COMPONENTS

3 Cuspidor Unit Section

■ Cuspidor Unit Control Panel

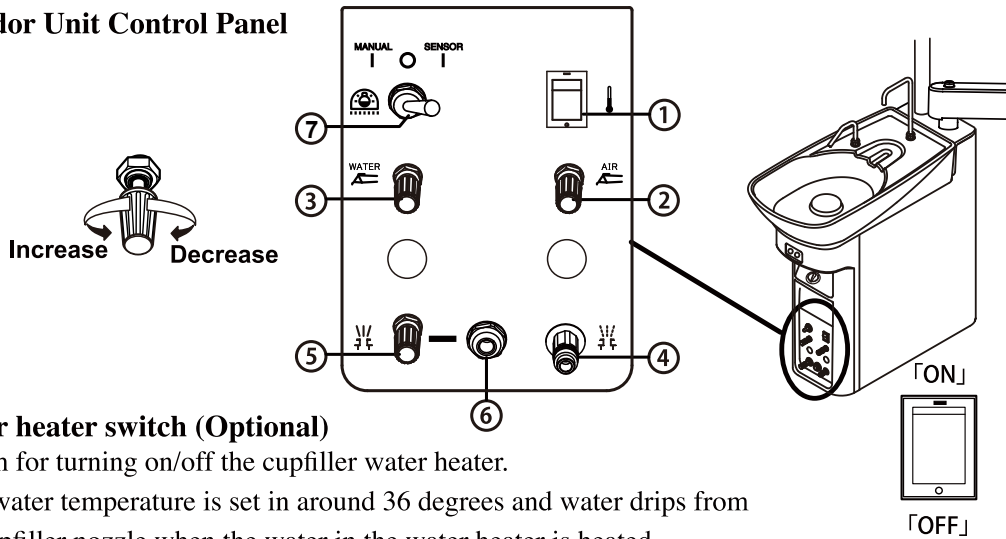

① Water heater switch (Optional)

Switch for turning on/off the cupfiller water heater.

(The water temperature is set in around 36 degrees and water drips from the cupfiller nozzle when the water in the water heater is heated.

This phenomenon is not a sign of failure.)

⚠ CAUTION

- Make sure that water is poured into the cup before turning on the heater unit in order to prevent the heater unit from heating the cup without water.
- Heating of an empty water heater may result in burning of the heater.

② Syringe air control

Make adjustment of syringe air by the syringe air control knob. (Please refer to page 23 for adjustment procedures)

③ Syringe water control

Make adjustment of syringe water by the syringe water control knob. (Please refer to page 23 for adjustment procedures)

④ Service outlet (air) (Optional)

Use this outlet to supply air to external equipment.

⑤ Service outlet water flow control (Optional)

Use this knob to control the water flow rate supplied to outside. (Please refer to page 23 for adjustment procedures)

⑥ Service outlet (water) (Optional)

Use this outlet to supply water to external equipment.

⑦ Dental light mode selection switch (EURUS LIGHT)

To operate by the touchless switch -----Set the switch lever to SENSOR Side.

To operate manually -----Set the switch lever to Manual Side.

Set the switch lever to Centre for OFF.

■ Assistant Control Panel (Chair Operation Switch) - Automatic Switch -

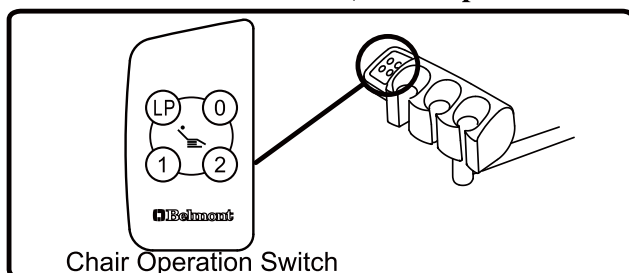

Chair Operation Switch

- Switches provide auto operation for preset switch, auto return switch and last position switch of the chair.
- The operation and function of the assistant control panel are the same as those on the doctor control panel in the doctor unit section.

DESCRIPTION OF OPERATION AND FUNCTIONS OF COMPONENTS

3 Cuspidor Unit Section

Assistant Control Panel

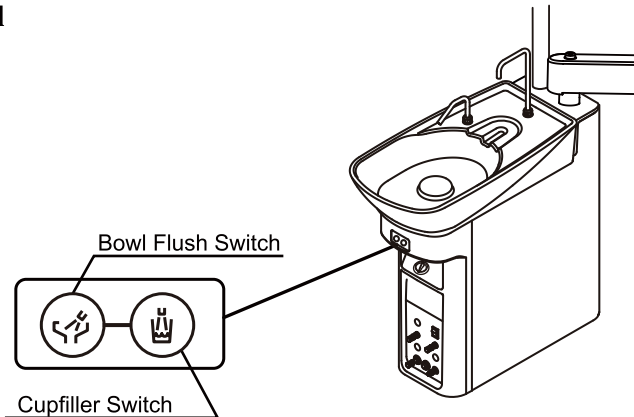

Cupfiller Switch

- Water is supplied through the cupfiller nozzle for certain time when this switch is pressed. Simultaneous with start-up of cupfiller motion, water comes out of the bowl flush nozzle and flushes the cuspidor bowl.
- * When the cupfiller switch is pressed, water is supplied automatically for certain time irrelevant to the water volume in the cup. Watch the overflow.
- * Do not press the switch while the cup is not in place.
- * In the case of sensor cupfiller (Optional), the water does not come out from the bowl flush nozzle when the cupfiller switch is pressed.

Bowl Flush Switch

- When this switch is pressed, water comes out of the bowl flush nozzle and flushes the cuspidor bowl.

Vacuum Handpiece

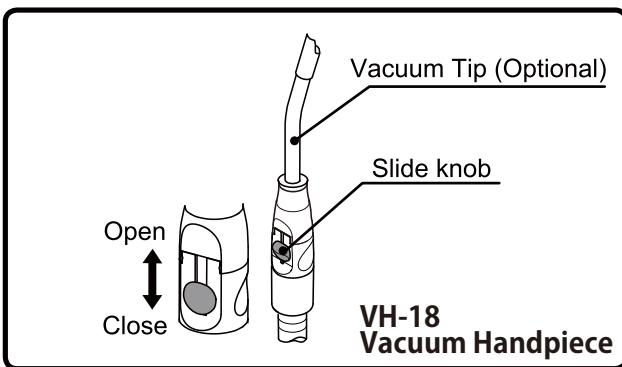

- Suction begins when the vacuum handpiece is taken out of the holder.
- Opening or closing the slide knob can control the suction flow rate.
- In case of the central vacuum system, suction will not stop immediately after the vacuum handpiece was returned to the holder, but suction will continue for about 3 seconds by the function of delay circuit.

Saliva Ejector Handpiece (Optional)

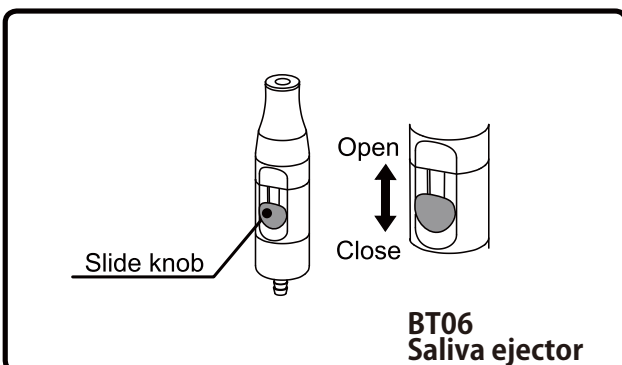

- Suction begins when the saliva ejector handpiece is taken out of the holder. Suction stop immediately when the saliva ejector handpiece is returned to holder.
- Opening or closing the slide knob can control the suction flow rate.
- In case of the central vacuum system, suction will not stop immediately after the vacuum handpiece was returned to the holder, but suction will continue for about 3 seconds by the function of delay circuit.

DESCRIPTION OF OPERATION AND FUNCTIONS OF COMPONENTS

3 Cuspidor Unit Section

■ Sensor Cupfiller (Optional)

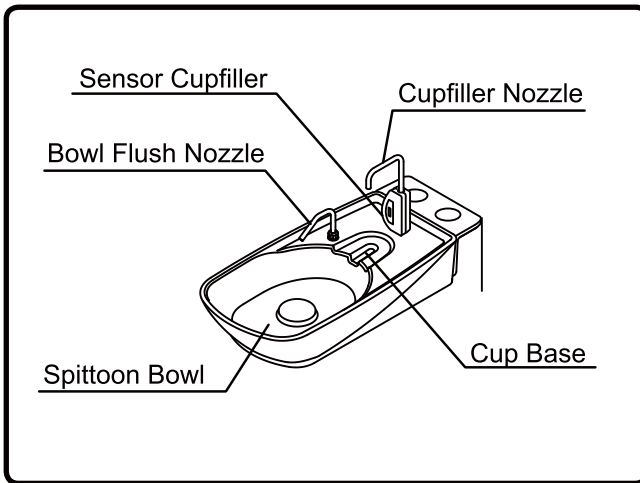

- Place the cup (paper cup) on the cupfiller base, water comes out from the cupfiller nozzle, fills up the cup and stops automatically. When cupfiller starts, the bowl flush also starts and stops automatically.

NOTICE

Use only suitable disposable paper cup (dental paper cup). Malfunction may arise if the cup is of another material grade or if the paper cup is of dark color or pattern. Recommend the use a white color paper cup.

■ Clean Water System (Optional)

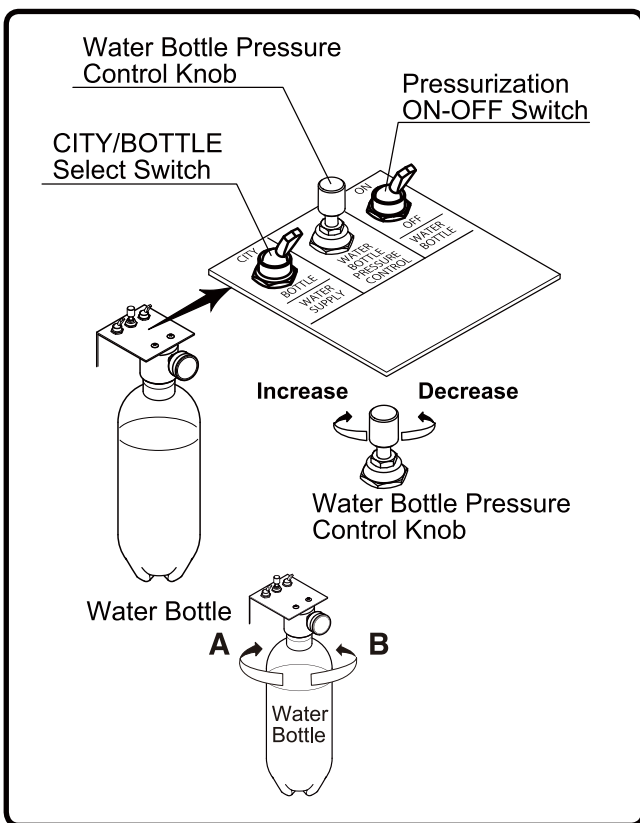

- The water bottle CITY/BOTTLE select switch can be changed between municipal water and water bottle.
CITY Tap water
BOTTLE Water bottle
- When the pressurization ON-OFF switch is set to ON, the water bottle may be used.
- The water bottle pressure control knob adjusts the pressure of water bottle. The pressure increase when the knob is turned clockwise, and decreases when the knob is turned counterclockwise.

Remove or attach the bottle

Turn off the pressurization ON-OFF switch. Water bottle may be remove by turned in direction A. It is attached when turned in direction B.

⚠ CAUTION

- The water tank is intended only for use with purified water, distilled water and pure water.
- Do not use mouthwash or electrolyzed water, as they may cause clogged tubing or affect internal valves and equipment.
- Adjust the air supply pressure for the water tank to 200 kPa or less. An excessively high pressure may cause damage to the water tank.

■ Dental Light

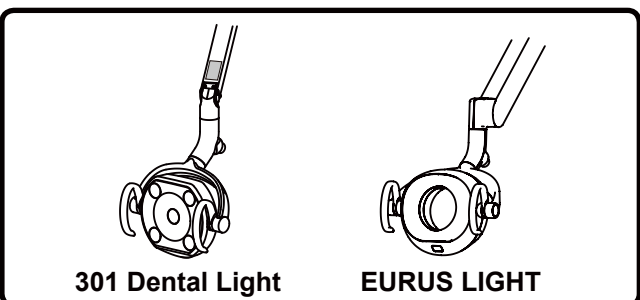

- Please refer to operating instruction for dental light.

DESCRIPTION OF OPERATION AND FUNCTIONS OF COMPONENTS

4 Utility Box Section

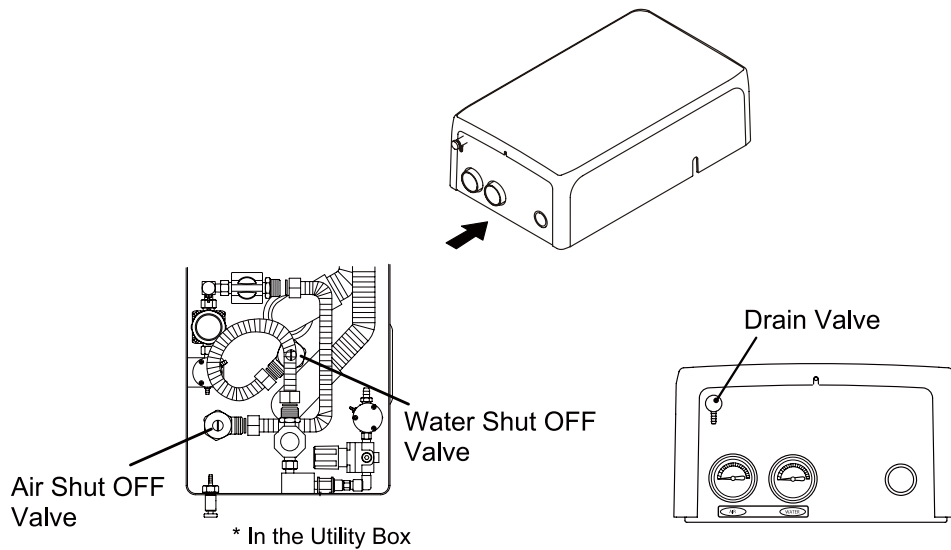

■ Air shut off valve

- The air can be stop by turning the shut off valve clockwise and open by turning the shut off valve counterclockwise.
- Use a flat head screwdriver to open and close the shut off valve.

■ Water shut off valve

- The water can be stop by turning the shut off valve clockwise and open by turning the shut off valve counterclockwise.
- Use a flat head screwdriver to open and close the shut off valve.

■ Drain Valve

- Drain valve is used to discharge water from the air filter.
- Use by hand to open and close the drain valve.

LOCK FUNCTION

■ Chair lock function

- The safety mechanism that inhibits chair motion works while any of the following actions is taken.
 1. Foot controller is being depressed.
 2. When any chair operation switch is depressed during automatic movement of the chair.

ADJUSTMENT OF PARTS

1 Doctor Unit Section

Flow Adjustment

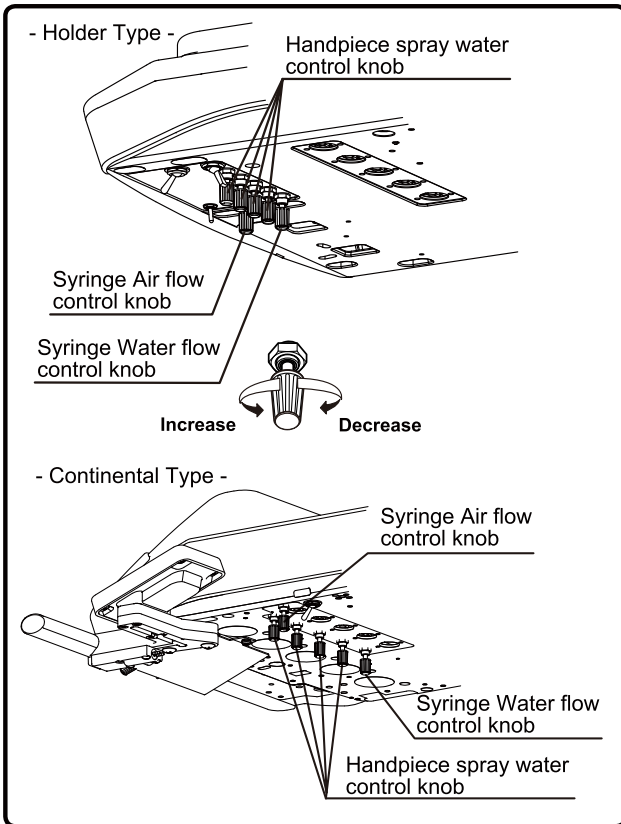

Water adjustment of the handpiece spray

- The water flow rates of the handpiece of the Doctor's unit may be adjusted with the knob (blue knob).
- Position of the adjustment knob corresponds to position of the instrument holder.

Water/air adjustment of the syringe spray

- The water and air flow rates of the syringe of the Doctor's unit may be adjusted with the knob.
Blue cap Water
Yellow cap Air
- * The flow rate is decreased by turning any knob clockwise. It is increased by turning the knob counterclockwise.
- * Flow rate adjustment knobs are intended to increase/decrease the flow rate, but do not serve as stop valves. Caution should be exercised as turning the knob excessively may cause it to loosen.

2 Cuspidor Unit Section

Flow Adjustment

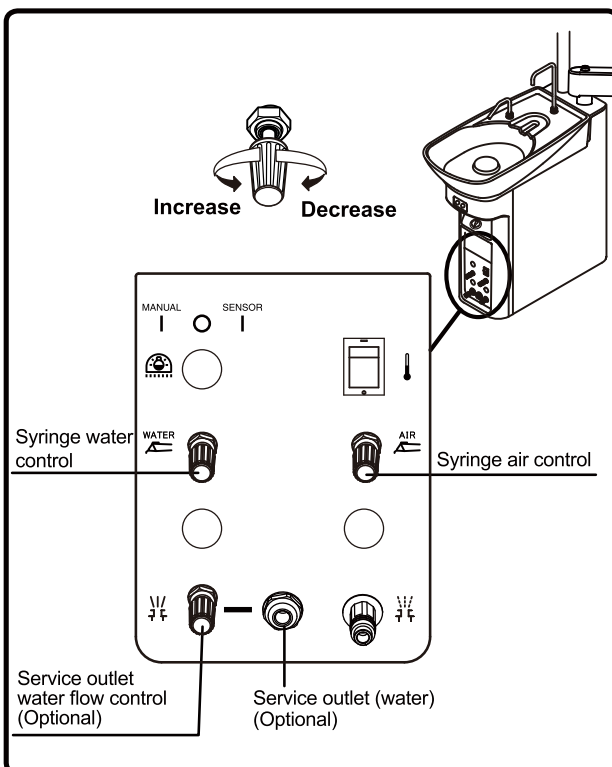

Service outlet water flow control (Optional)

- Use this knob to control the water flow rate supplied to outside.

Water/air adjustment of the syringe spray

- The water and air flow rates of the syringe of the cuspidor unit may be adjusted with the knob.
Blue cap Water
Yellow cap Air
- * Flow rate adjustment knobs are intended to increase/decrease the flow rate, but do not serve as stop valves. Caution should be exercised as turning the knob excessively may cause it to loosen.

ADJUSTMENT OF PARTS

2 Cuspidor Unit Section

Flow Adjustment

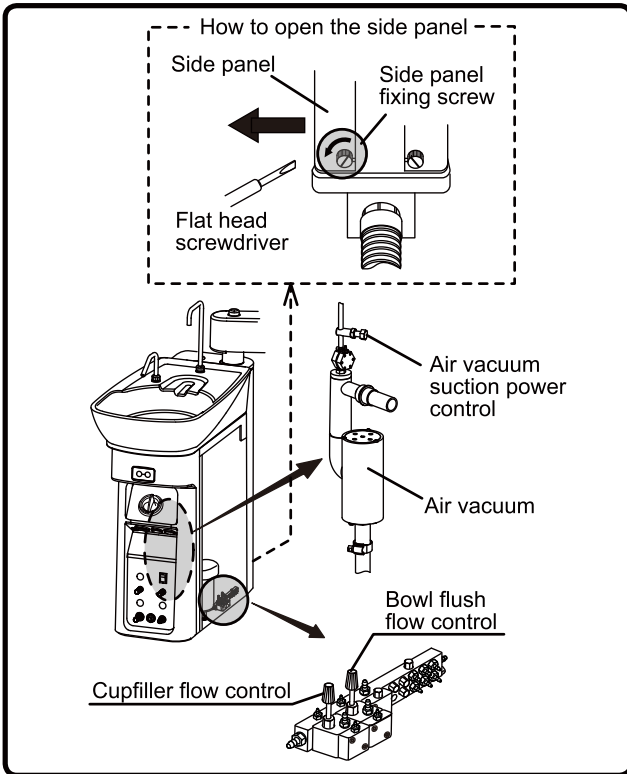

* Flow control knobs are located on the inside of the cuspidor unit. Loosen the side panel fixing screw by flat head screwdriver on the rear side of the cuspidor unit. Open the side panel to outside as shown on the left figure.

Cupfiller Flow Control

- This knob adjusts the water feeding quantity.
- The flow rate decreases when the knob is turned clockwise, and the flow rate increases when the knob is turned counterclockwise.

Bowl Flush Flow Control

- This knob adjusts the flow rate of bowl flush.
- The flow rate decreases when the knob is turned clockwise, and the flow rate increases when the knob is turned counterclockwise.

Air Vacuum Suction Power Adjustment (Optional)

- This knob adjusts the suction power of the air vacuum.
- The suction power decreases when the knob is turned clockwise and increases when the knob is turned counterclockwise.

3 Utility Box Section

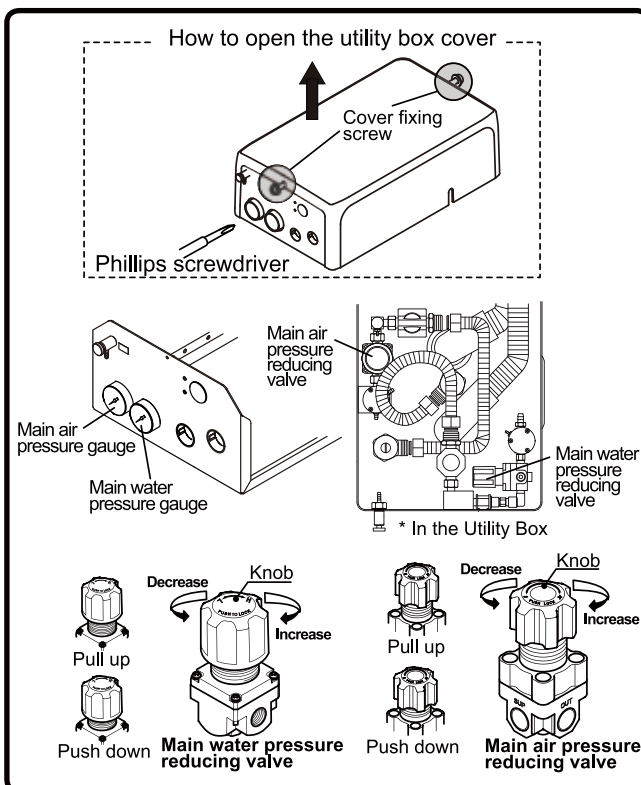

* The pressure adjustment valves are located on the inside of the utility box. Loosen the two cover fixing screws by phillips screwdriver and remove the utility box cover as shown on the lift figure.

Main air pressure reducing valve

- This knob adjusts the main pressure of air supplied to the unit.
- Pull the knob and turn as shown in the drawing so that the main air pressure gauge reads a value between 0.45 and 0.5 MPa.
- Be sure to push the knob to lock it after setting.
- This knob is adjusted when installing the unit.
Do not change the setting under normal conditions.

Main water pressure reducing valve

- This knob adjusts the main pressure of water supplied to the unit.
- Pull the knob and turn as shown in the drawing so that the main water pressure gauge reads a value between 0.1 and 0.2 MPa.
- Be sure to push the knob to lock it after setting.
- This knob is adjusted when installing the unit.
Do not change the setting under normal conditions.

CARE AND MAINTENANCE

1 Doctor Unit Section

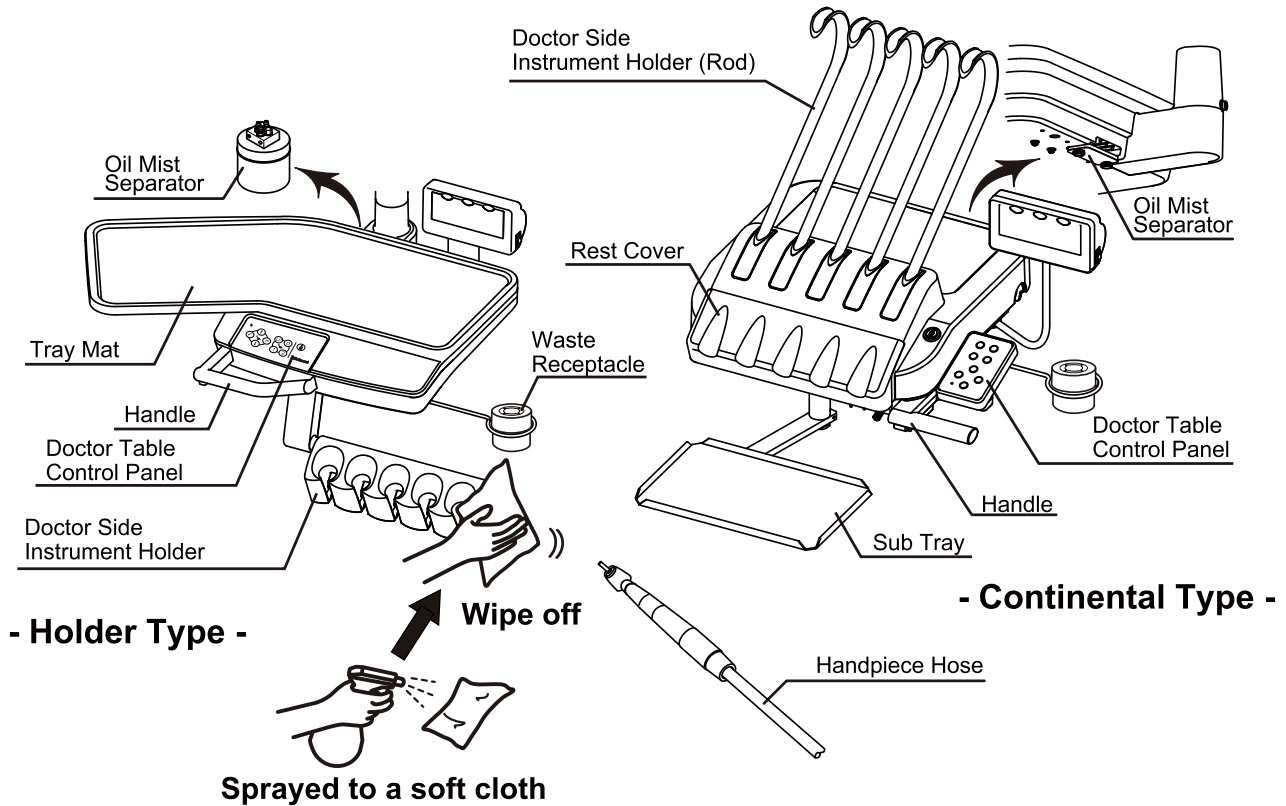

■ Doctor Instrument Holder, Doctor Control Panel, Handle, Tray Mat, Sub Tray, Rest Cover, Handpiece Hose

- Wipe off the surface with soft cloth moistened with cleaner or disinfectant. Wipe off with dry soft cloth to dried up after cleaning and disinfection.
 - Use the cleaner and disinfectant FD333/FD366 made by Durr. (Spray disinfectant mainly composed of disinfection ethanol and wipe it off, when general disinfectant is used.)
- Also, read carefully and observe instructions of cleaner or disinfectant before use.

⚠ CAUTION

When the surface of the operation panel is cleaned with disinfectant, etc., wipe off disinfectant completely. If it penetrates into the back of the sheet, the membrane switches may malfunction.

NOTICE

Observe the instructions given in the package insert and Instruction Manual included with the handpiece to clean it.

CARE AND MAINTENANCE

1 Doctor Unit Section

Waste Receptacle (Optional)

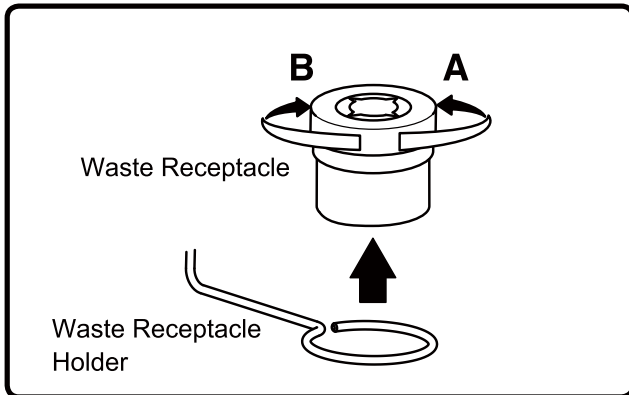

- Dispose of waste material and clean it when waste accumulates.
- The stainless waste receptacle may be detached when it is turned in direction A. It is fastened when turned in direction B. The lid has sharp portions that can easily catch cotton, etc. Be very careful when cleaning it.

Oil Mist Separator

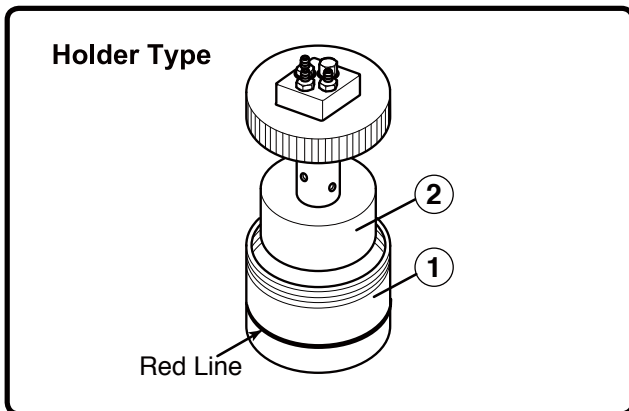

Holder Type

- The Oil mist separator collects oil contained in exhaust air from the handpieces.
- When oil reaches to the red line on the oil reservoir container (1), make sure you discard the oil.
- Turn the oil reservoir container counterclockwise to remove.
If the hygroscopic sponge (2) (consumable) is excessively dirty or has excessive oil on it, replace it.

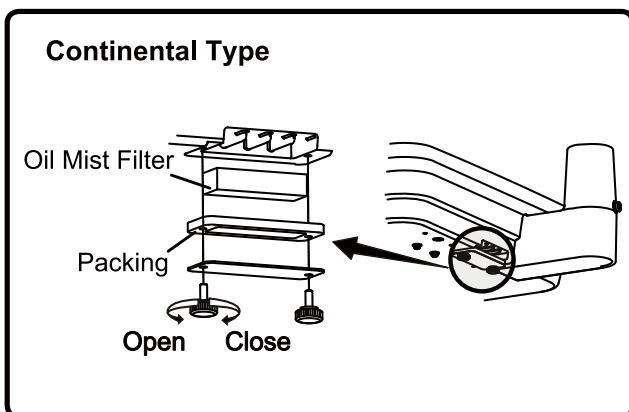

Continental Type

- The oil mist separator collects oil contained in exhaust air from the handpieces.
- Be sure to clean the oil mist filter once a month. The oil mist filter can be detached by removing two screws.
- Replace the oil mist filter if a lot of dirt or oil adheres to it.

CARE AND MAINTENANCE

2 Cuspidor Unit Section

■ Cleaning of spittoon section

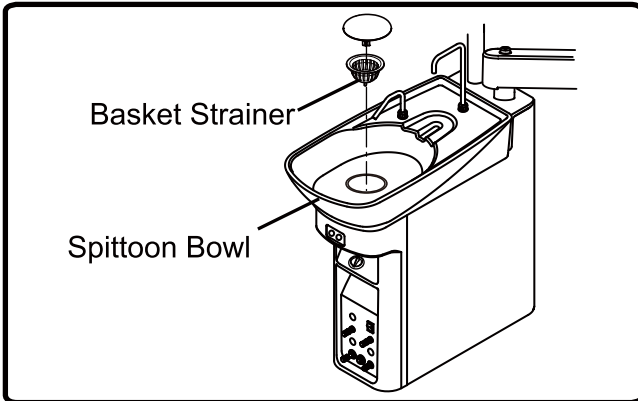

- Use Orotol Plus made by Durr to cleaning the spittoon bowl.
- The basket strainer in the spittoon bowl is easily clogged. Clean it at the end of each work day.

⚠ CAUTION

- **Never use sandpaper, metal scrub brushes and abrasive cleaning agents to clean the spittoon bowl.**
- **The spittoon bowl is made of ceramic. It may break if it is impacted. Do not wash it with hot water. Otherwise, it may break.**

■ Cleaning of the solid collector

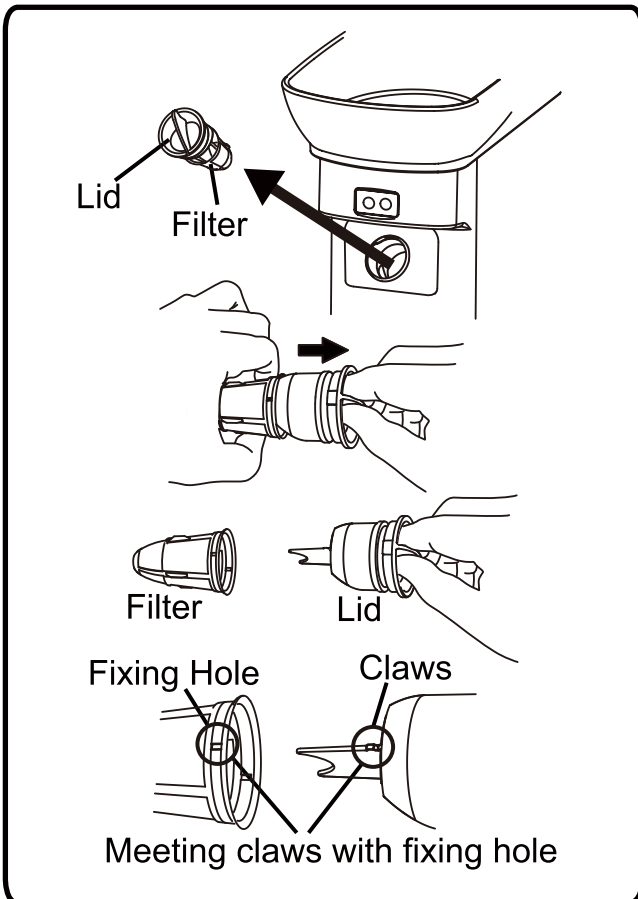

- Detach and wash the filter in the solid collector of the cuspidor unit at the end of each work day.
- If sucked substances are collected, the suction force of the vacuum is reduced.

【Detach / Attach the filter】

1. Pull out and detach the lid from solid collector.
2. Separate the lid and the filter by pulling the lid as shown in the left figure.
3. Clean the filter and lid with running water.
4. Attach the lid to the filter by meeting claws of the lid with fixing hole of the filter.
5. Attach the filter in the reverse order.

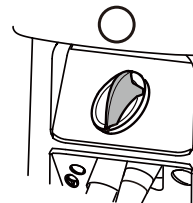

Correct direction
Obtuse shape of knob is on upper side

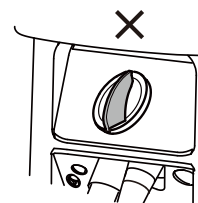

Wrong direction
Acute shape of knob is on upper side

⚠ CAUTION

Be sure to firmly inset the solid collector in the correct direction. If not, vacuum and saliva ejector may not work properly.

■ Cleaning of vacuum / saliva ejector lines

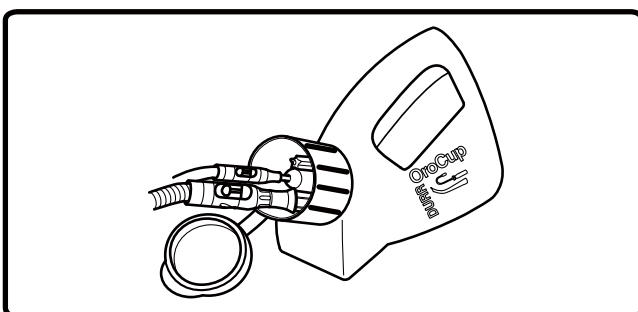

- The sucking unit comes into contact with secretions, spit and blood that contain bacteria every day. Be sure to clean and sterilize it with Orotol Plus made by Durr at the end of each work day.

⚠ CAUTION

Do not use strongly acidic cleaning agents or alkaline pipe cleaning agents, which may cause corrosion of metals, etc/

CARE AND MAINTENANCE

2 Cuspidor Unit Section

■ Cleaning of vacuum hose / saliva ejector hose

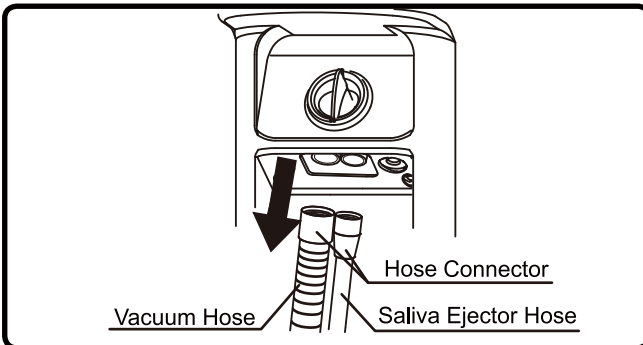

- The vacuum hose and saliva ejector hose can be disconnected by pulling downward direction, as arrows is shown on the left figure. Clean hoses in running water.
Be sure to turn off the main switch of the unit before cleaning.
- Replace with a new vacuum hose and saliva ejector hose if damage occurs or dirt on the hose becomes conspicuous.

■ Cleaning of Vacuum Handpiece / Saliva Ejector Handpiece

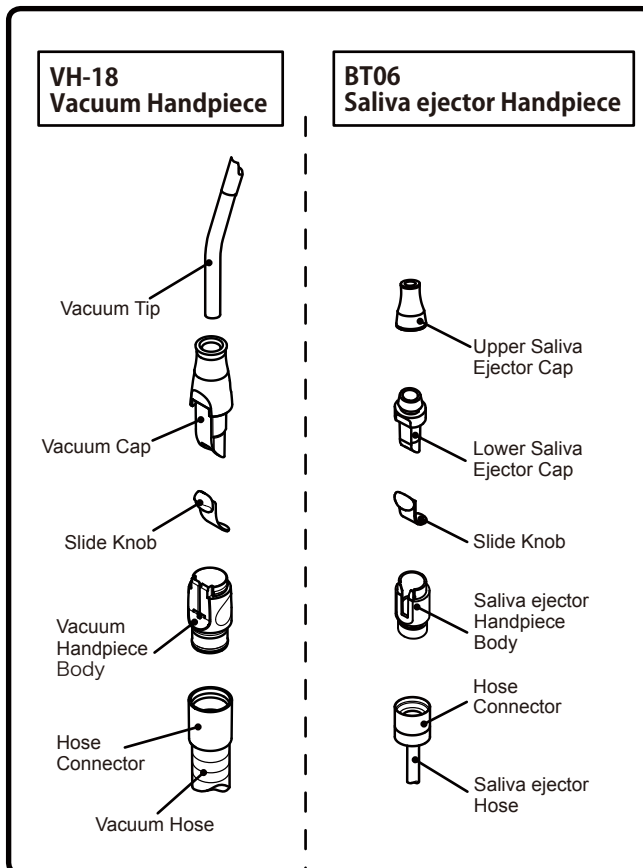

- * Cleaning and sterilization must be done every after use to patients.
- For effective sterilization, washing for removing contamination and immersion by a cleaning agent are required. Then, rinse by water in order to remove residual cleaning agent on medical device. Take following procedures from cleaning to sterilization.
- * Use the disposable saliva ejector tip.

【Disassembly】

Disassemble the handpiece for the preparation of cleaning as the following figures show.
Pull the hose connector to disconnect the vacuum hose.

【Cleaning by hand】

1. Wipe off the surface contamination by a cloth while rinsing the surface by running clean warm water at 40±5 degrees. Scrub the intubation or hole, slide groove and filter by a cleaning brush or by a tooth brush with running clean warm water at 40±5 degrees. Wipe off by a cloth for the area which brush is unable to reach..
2. Check whether contamination is removed or not after cleaning. Continue the cleaning if contamination is remained.
3. Immersed with an alkaline detergent for 5 minutes. (We recommend to use ID212 made by Durr)
4. Rinse thoroughly by distilled water at ordinary temperature or by clean water for more than 1 minute.

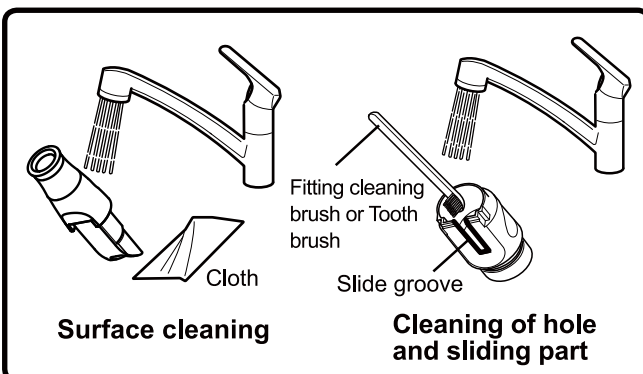

CARE AND MAINTENANCE

2 Cuspidor Unit Section

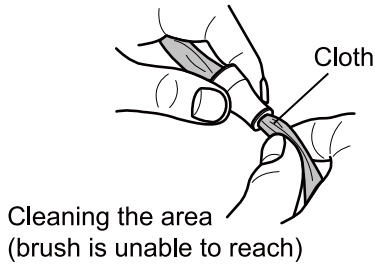

⚠ CAUTION

Cleaning must be done within 1 hour after use. Replace with a new vacuum handpiece and saliva ejector handpiece for following cases.

- Any waste material can not be removed by clogged hole.
- Contamination and solid material attached to vacuum handpiece and saliva ejector can not be removed.

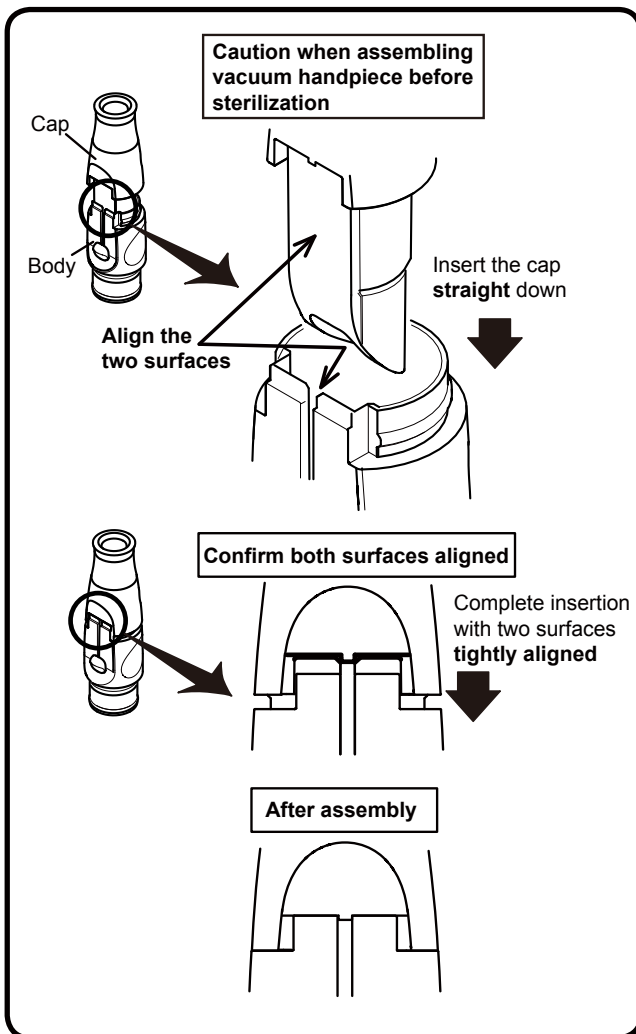

【Assembly before sterilization】

Vacuum Tip/Vacuum Handpiece/Saliva Ejector Handpiece can be autoclave. Vacuum handpiece and saliva ejector handpiece have to assemble before autoclave.

When assembling the vacuum handpiece, align the two surfaces; a flat surface of the cap and the surface of the sliding groove of the body. Then, slide the cap into the body straight.

* Do not insert it twisted.

CARE AND MAINTENANCE

2 Cuspidor Unit Section

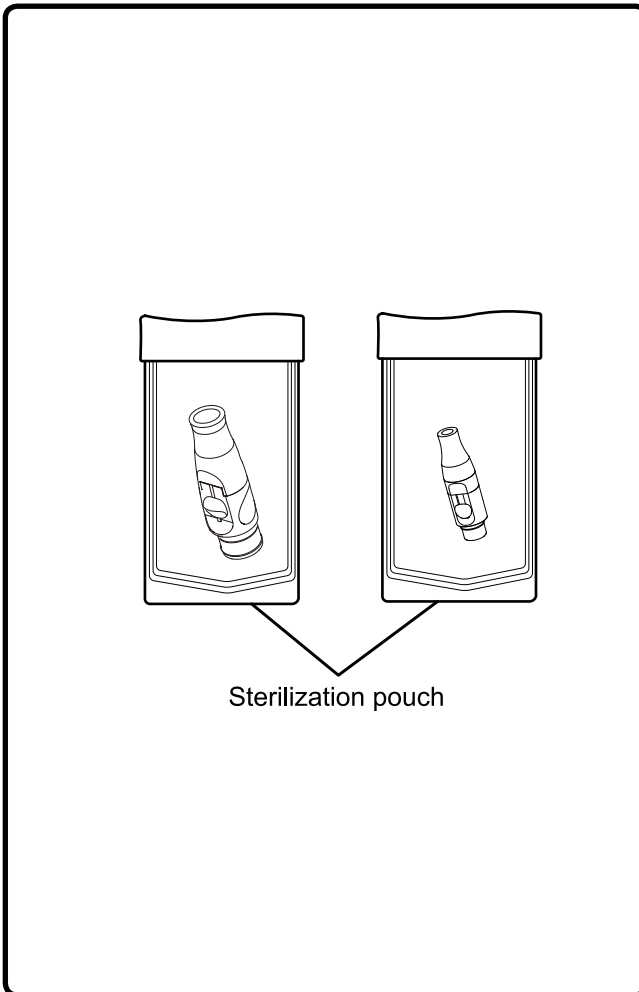

【Sterilization】

Vacuum tip/Vacuum handpiece/Saliva ejector handpiece can be autoclave. Vacuum handpiece and saliva ejector handpiece have to assemble before autoclave.

1. Insert the handpiece in a sterilization pouch and seal it.
 2. Autoclave for 3 min. at 134°C and dry for 15 min.
- * Sterilization with autoclave is permitted up to 250 times.

⚠ CAUTION

- Sterilization by class B cycles.
- Sterilization temperature is 135 degrees or less.
- Skip the drying process if the temperature is to exceed 135°C.
- The cap, filter and body are made of resin. They may become deteriorated if they are sterilized in an autoclave many times.
- After autoclave sterilization, the cap, filter, body and valve are subject to discoloration, which does not have a negative effect on performance.
- The slide knob can be autoclave 100 times and is expendable supplies.
- If damage occurs to the sterilization pouch, discard and sterilize again using a new pouch.

【Storage】

After sterilizing the vacuum tip, keep it in the sterilization pouch and store in a dark and cold place.

■ Assistant Instrument Holder, Assistant Control Panel, Assistant Sub Tray(Optional)

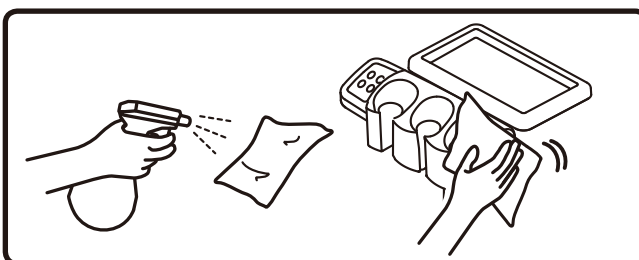

- Wipe off the holder surface with soft cloth moistened with cleaner or disinfectant. Wipe off with dry soft cloth to dried up of the holder after cleaning and disinfection.
- Use the cleaner and disinfectant FD333/FD366 made by Durr. (Spray disinfectant mainly composed of disinfection ethanol and wipe it off, when general disinfectant is used.). Also, read carefully and observe instructions of cleaner or disinfectant before use.

⚠ CAUTION

When the surface of the operation panel is cleaned with disinfectant, etc., wipe off disinfectant completely. If it penetrates into the back of the sheet, the membrane switches may malfunction.

NOTICE

Observe the instructions given in the package insert and Instruction Manual included with the handpiece to clean it.

CARE AND MAINTENANCE

3 Utility Box Section

■ Cleaning air filter drain valve and discharging water from air compressor

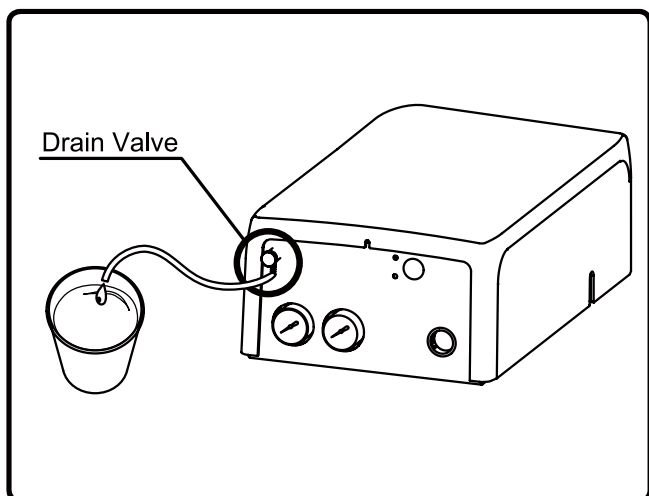

- Drain valve is used to discharge water from the air filter.
- Connect the tubing to the drain valve and prepare the water pan such as paper cup. Turn the drain valve counterclockwise to discharge water collected in the air filter once a week at least.
- If water enters the unit, the air turbine, air motor or syringe, etc., may become defective. Be sure to turn the drain valve clockwise to close the valve after discharging water from the air filter.
- Open the drain valve of the air compressor to discharge collected water once a week according to the instruction manual of the compressor. It is recommend that the compressor with air dryer or auto drain function for use.

■ Filter Replacement

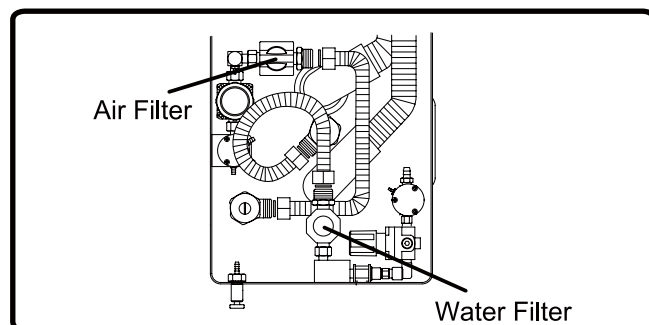

- The water filter in the utility box needs to be replaced at least once a year.
- The air filter in the utility box needs to be replaced at least once every three years. Contact your local service representative for replacement.

4 Product Exterior

■ Cleaning and Sterilization of product exterior

- Clean the metallic parts with a dry soft cloth.
Wipe off water immediately if water is put on the product. Water may cause rusting.
- Clean the resin parts with a wet soft cloth.
- Use FD333 or FD366 made by Durr or ethanol for cleaning and bacteria elimination from the product exterior.

CAUTION

- Wipe off water and residual disinfectant immediately. This could cause corrosion, damage or incorrect operation of the unit.
- Immediately wipe off any water spills or leakage on the floor. This could cause damage to the product, decreased strength of the floor may lead to physical injury including fall, or property damage.

SPECIFICATIONS

Rated power voltage / Power input (Without dental light)	: AC230V 50Hz/60Hz ... 1.4A (Dental unit) ... 3.6A (Dental unit with chair)
Fuse	: 5A/250V Low Breaking Capacity, Time-lag Size : 5.0 x 20mm
Main air pressure	: 0.45 ~ 0.5 MPa
Main water pressure	: 0.1 ~ 0.2 MPa
Weight	: 70kg (without dental light) Over the Patient, Holder Type : 71kg (without dental light) Over the Patient, Continental Type : 80.7kg (without dental light) Cart Type
Load Capacity	: Doctor Table 2kg (Over the Patient, Holder Type/Cart Type) : Sub Tray 1.5kg (Over the Patient, Continental Type) : Assistant Sub Tray 1.5kg
Dental Light	: 301 Dental Light : EURUS LIGHT
Usage environment	: Temperature 0°C ~ +40°C : Humidity 10% to 95% : Air pressure 700 hPa ~ 1060 hPa
Transportation / Storage environment	: Temperature -20°C ~ +70°C : Humidity 10% ~ 95% : Air pressure 700 hPa ~ 1060 hPa
Service life	: 10 Years
Classification of foot controller	: IPX1(applicable standard IEC60529)
Protection class against electric shock	: Class I equipment
Applied part	: type B applied part: Handpiece
Equipment not suitable for use in the presence of a flammable anesthetic mixture with air or with oxygen or nitrous oxide.	

Dimensions

Over the Patient Type

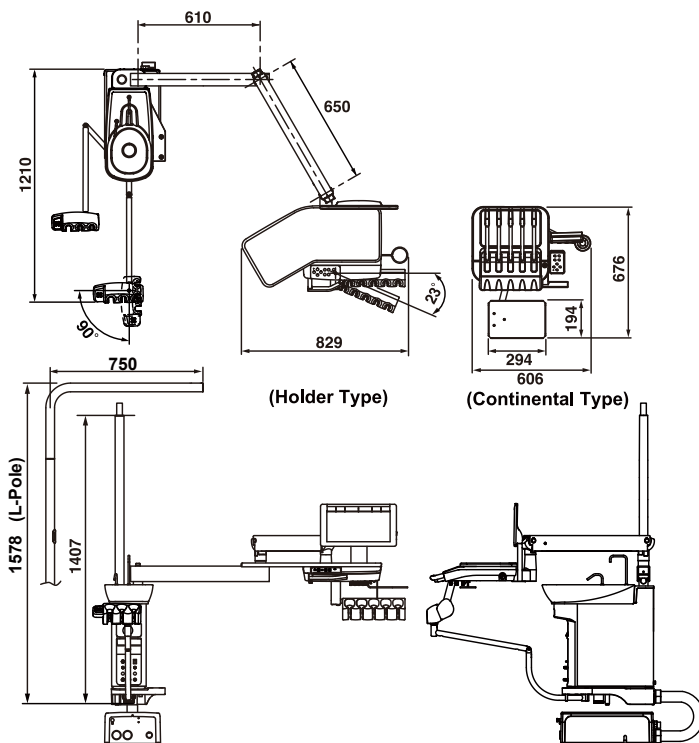

Values are the standard values. (Unit: mm)

Dimensional tolerance: ±10%

Cart Type

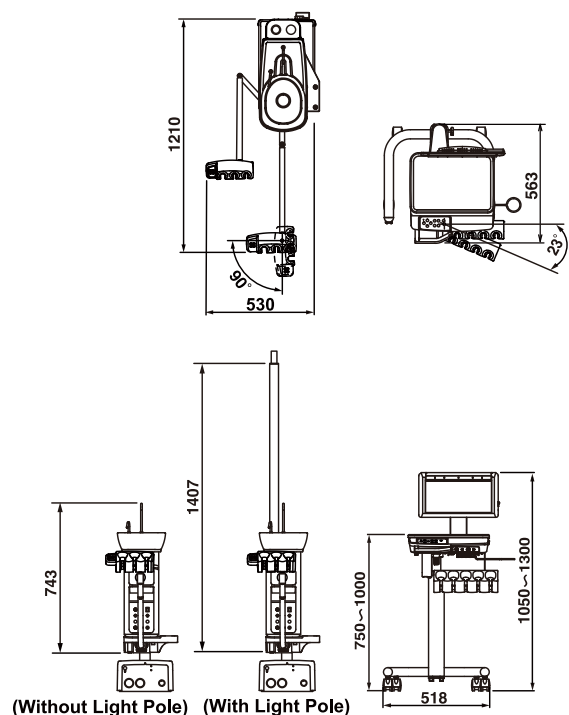

ELECTROMAGNETIC COMPATIBILITY (EMC)

This product complies with EMC Standard EN60601-1-2:2015.

1. Precautions regarding EMC and compliance with accompanying documents

Medical electrical equipment requires special precautions regarding EMC and needs to be installed and put into service according to the EMC information provided in this booklet.

2. Effects of RF communication devices

Portable and mobile RF communication devices can affect medical electrical equipment.

3. Installation exclusion environment

Hospitals except for near active HF SURGICAL EQUIPMENT and the RF shielded room of an ME SYSTEM for magnetic resonance imaging, where the intensity of EM DISTURBANCES is high.

4. Electromagnetic emission declaration

Guidance and manufacturer's declaration – electromagnetic emissions		
The CLESTA eIII Unit is intended for use in the electromagnetic environment specified below. The customer or user of the CLESTA eIII Unit should ensure that it is used in such an environment.		
Emissions test	Compliance	Electromagnetic environment - guidance
RF emissions CISPR 11	Group 1	The CLESTA eIII Unit only uses RF energy for its internal function. Therefore, its RF emissions are very low and are not likely to cause any interference with nearby electronic equipment.
RF emissions CISPR 11	Class B	The CLESTA eIII Unit is suitable for use in all establishments, including domestic establishments and those directly connected to the public low-voltage power supply network that supplies buildings used for domestic purposes.
Harmonic emissions IEC 61000-3-2	Class A	
Voltage fluctuations/ Flicker emissions IEC 61000-3-3	Complies	

WARNING

Use of this equipment adjacent to or stacked with other equipment should be avoided because it could result in improper operation. If such use is necessary, this equipment and the other equipment should be observed to verify that they are operating normally.

5. Electromagnetic immunity declaration 1

Guidance and manufacturer's declaration – electromagnetic immunity			
The CLESTA eIII Unit is intended for use in the electromagnetic environment specified below. The customer or user of the CLESTA eIII Unit should ensure that it is used in such an environment.			
Immunity test	IEC 60601 test level	Compliance level	Electromagnetic environment - guidance
Electrostatic discharge (ESD) IEC 61000-4-2	±8 kV contact ±15 kV air	±8 kV contact ±15 kV air	Flooring should be wood, concrete, or ceramic tiles. If the floor is covered with synthetic material, the relative humidity should be at least 30%.
Electrical fast transient/burst IEC 61000-4-4	±2 kV for power supply lines ±1 kV for input/output lines	±2 kV for power supply lines ±1 kV for input/output lines	The mains power quality should be that of a typical commercial or hospital environment.
Surge IEC 61000-4-5	±1 kV differential mode ±2 kV common mode	±1 kV differential mode ±2 kV common mode	The mains power quality should be that of a typical commercial or hospital environment.
Voltage dips, short interruptions and voltage variations on power supply input lines IEC 61000-4-11	0% UT ; 0.5 cycles 0°, 45°, 90°, 135°, 180°, 225°, 270° and 315° 0% UT ; 1 cycle and 70% UT ; 25/30 cycles at 0°, single phase 0% UT ; 250/300 cycles	0% UT ; 0.5 cycles 0°, 45°, 90°, 135°, 180°, 225°, 270° and 315° 0% UT ; 1 cycle and 70% UT ; 25/30 cycles at 0°, single phase 0% UT ; 250/300 cycles	The mains power quality should be that of a typical commercial or hospital environment. If the user of the CLESTA eIII Unit requires continued operation during mains power interruptions, it is recommended that the CLESTA eIII Unit be powered from an uninterruptible power supply or a battery.
Power frequency (50/60 Hz) magnetic field IEC 61000-4-8	30 A/m	30 A/m	Power frequency magnetic fields should be at levels characteristic of a typical location in a typical commercial or hospital environment.
Note U_T is the AC mains voltage prior to the application of the test level.			

ELECTROMAGNETIC COMPATIBILITY (EMC)

6. Electromagnetic immunity declaration 2

Guidance and manufacturer's declaration – electromagnetic immunity			
The CLESTA eIII Unit is intended for use in the electromagnetic environment specified below. The customer or user of the CLESTA eIII Unit should ensure that it is used in such an environment.			
Immunity test	IEC 60601 test level	Compliance level	Electromagnetic environment - guidance
Conducted RF IEC 61000-4-6	3V 0.15MHz~80MHz 6V 0.15MHz~80MHz in ISM and amateur radio bands	3V 0.15MHz~80MHz 6V 0.15MHz~80MHz in ISM and amateur radio bands	Warning: Portable RF communications equipment (including peripherals such as antenna cables and external antennas) should be used no closer than 30 cm (12 inches) to any part of the CLESTA eIII, including cables specified by the manufacturer. Otherwise, degradation of the performance of this equipment could result.
Radiated RF IEC 61000-4-3	3V/m 80MHz~2.7GHz 80% AM (1 kHz)	3V/m 80MHz~2.7GHz 80% AM (1 kHz)	
Near electromagnetic field caused by RF wireless communication devices IEC 61000-4-3	See the table below	See the table below	

7. Essential performance

Unless operated by the chair control switch, the chair will not make any movements. Unless operated by the foot controller, the handpiece will not move except for sounding a buzzer and switching the indicator on/off. Loss or decline of essential performance may cause the chair or handpiece to move unexpectedly, causing harm to the patient, operator or people or objects around the patient or operator.

WARNING

Portable RF communications equipment (including peripherals such as antenna cables and external antennas) should be used no closer than 30 cm (12 inches) to any part of the CLESTA eIII, including cables specified by the manufacturer.

Otherwise, degradation of the performance of this equipment could result.

Near electromagnetic field caused by RF wireless communication devices

Test frequency (MHz)	Modulation	IEC 60601 test level	IEC 60601 compliance level
385	Pulse modulation ^{a)} 18Hz	27V/m	27V/m
450	Frequency modulation ±5kHz shift 1kHz sine wave	28V/m	28V/m
710 745 780	Pulse modulation ^{a)} 217Hz	9V/m	9V/m
810 870 930	Pulse modulation ^{a)} 18Hz	28V/m	28V/m
1720 1845 1970	Pulse modulation ^{a)} 217Hz	28V/m	28V/m
2450	Pulse modulation ^{a)} 217Hz	28V/m	28V/m
5240 5500 5785	Pulse modulation ^{a)} 217Hz	9V/m	9V/m
Note a) The carrier is modulated by a square wave with a 50% duty cycle.			

HANDPIECES THAT CAN BE USED WITH THIS PRODUCT

Syringe	DCI (3-way) SYRINGE (3439 Quick clean standard syringe) (3459 Quick clean continental syringe)
Turbine	NSK Ti-Max X
Air motor	NSK EX-203 / EX-6
Micromotor	NSK NBX / iMD PCB. / EX-6 (Only Holder Type)
	BIEN AIR MCX / DMCX PCB. / PM 1:1
Scaler	SATELEC NEWTRON LED / SP4055 NEWTRON Module + LED Drive Board
	NSK VARIOS 170 w/LED
	XINETIC SCALER
	EMS NO PAIN SCALER

IMPORTANT

The connectors of our handpiece hose are designed and manufactured in accordance with ISO9168:2009 (DENTISTRY-HOSE CONNECTORS FOR AIR DRIVEN DENTAL HANDPIECES).

However, there still could be a case that the connectors of turbines or air motors may not fit into some handpieces due to the manufacturing tolerances.

Have your local authorized Belmont dealer check the connectability before purchasing the handpiece. Except for our recommended handpieces, we shall not be liable for any problems deriving from bad connectability or their performance.

CHAIR THAT CAN BE USED WITH THIS PRODUCT

Chair	Clesta eIII CHAIR
-------	-------------------

DENTAL LIGHT THAT CAN BE USED WITH THIS PRODUCT

Dental Light	301 Dental Light
	EURUS LIGHT

BEFORE ASKING FOR REPAIRS

If any of phenomena described below has occurred, make the following checks before asking for repairs.

Phenomenon	Check point and result	Action to be taken
No power on the unit	Equipment circuit breaker in the clinic cabinet panel is not on.	Turn on the equipment circuit breaker.
	Air compressor power is not on.	Turn on the power.
Water is not supplied.	Confirm main water pressure gauge (Normal pressure = 0.1 - 0.2 MPa)	Open the water shut off valve.
		Adjust the main water pressure.
No water from handpiece	Handpiece water adjustment knob is closed	Open the knob.
Turbine does not run	Confirm main air pressure gauge (Normal pressure = 0.45 - 0.5 MPa)	Adjust the main air pressure.
	If air comes out from turbine hose.	Turbine failure (Refer to instruction manual of turbine)
No water or air from syringe	Syringe water or air adjustment knob is closed	Open the knob.
Vacuum suction / Salive ejector does not suck	Slide knob is closed.	Open the slide knob.
	Handpiece filter is contaminated.	Clean the filter.
	Solid collector filter is contaminated.	Clean the filter.
	Power of the vacuum pump has not been turned on.	Turn on the power.

If the unit does not normally work even if actions were taken upon checkup stated above, then stop using the unit, turn off the main switch and contact your dealer or our office.

STORAGE METHOD

Strictly observe the following points when the product will not be used for a long period of time (following the completion of work, during the suspension of business, etc.).

1. Main switch

- Be sure to turn off the main switch at the end of each work day . (To stop supply of air, water, electric power, etc.)
- Strictly observe this instruction to prevent water leakage and electric accidents.

2. Water main valve

- Be sure to turn the main water valve counterclockwise to the Close position at the end of each work day.

3. AIR main valve

- Be sure to turn the main air valve counterclockwise to the Close position at the end of each work day.

4. Be sure to turn off the compressor breaker and then discharge air from the compressor. (Be sure to turn off the power.)

5. Be sure to turn off the vacuum pump breaker. (Be sure to turn off the power.)

6. Be sure to turn off the equipment breaker on the clinic's electrical panel. (Be sure to turn off the power.)

MAINTENANCE AND INSPECTION

Guide for daily maintenance and inspection (Maintenance and inspection by user)

- Management of maintenance and inspection of medical equipment should be implemented by the user (medical institution).
- For safe use of this product, it is necessary that inspection should be conducted in the specified frequency on the items described below.

No.	Item	Frequency	Inspection method and diagnosis	Influence if inspection not conducted	Maintenance required in case of nonconformity
1	Check of safety functions	Before start	Make sure the chair movement stops by any of the following actions. ① when foot controller pedal is depressed. ② During chair auto movement, depress of any operation switches for the chair.	Unexpected personal injury and troubles may arise due to motion of the chair during medical treatment and due to pinching between doctor section and chair.	Contact your dealer or our office if any abnormality arises.
2	Check of water pressure and air pressure	Before start	Check the water pressure and air pressure by reading pressure gauges in the U-Box section. Basic set pressure : Water: 0.1 to 0.2 MPa Air: 0.45 to 0.5 MPa	The product will not normally work, and troubles may arise.	Contact your dealer or our office if the set pressure is abnormally high or low.
3	Check for leakage of water, air and oil	Before start	Leakage of water, air and oil shall not be observed around the product.	The product will not normally work, and troubles may arise.	Contact your dealer or our office if any abnormality arises.
4	Check of conditions of table section	Before start	The table shall be free of inclination, and shall not drift of the table.	Injury caused by falling of goods located on the table and other troubles may arise.	Contact your dealer or our office if any abnormality arises.
5	Check of panorama size viewer	Before start	Check the light turn ON - OFF and dimmer is adjustable. The light shall not blinking continuously.	Viewer doesn't function.	Contact your dealer or our office if any abnormality arises.
6	Check of dental size viewer	Before start	Check the light turn ON and OFF. The light shall not blinking continuously.	Viewer doesn't function.	Contact your dealer or our office if any abnormality arises.
7	Check of operation switch	Before start	The product operation switch is functions correctly. *Refer the operating instruction for switch operating.	Product failure and troubles may arise.	Contact your dealer or our office if any abnormality arises.
8	Check of handpiece light	Before start	Turn on the handpiece light on/off switch. The handpiece light shall be on when taken from holder.	Handpiece light will not light up.	Replace lamp accordance with the instruction manual attached to individual handpiece. Contact your dealer or our office if there is no improvement in symptoms after replaced lamp.
9	Check of motions of turbine/air motor	Before start	Air turbine/air motor revolution, water flow, air flow and so forth shall be free of abnormality. [Reference] 0.22Mpa pressure in table Turbine more than 300,000rpm 0.32Mpa pressure in table Air motor more than 20,000rpm Setting and Performance will be difference according to the type of handpiece. Refer to the instruction manual attached to individual handpiece.	Troubles such as injury in patient's oral cavity and equipment failure may arise.	Control the water flow in accordance with page:23 "Adjustment of Parts" described in the instruction manual. Contact your dealer or our office if recovery is not achieved.

MAINTENANCE AND INSPECTION

No.	Item	Frequency	Inspection method and diagnosis	Influence if inspection not conducted	Maintenance required in case of nonconformity
10	Check motions of scaler	Before start	Scaler vibration, water flow and so forth shall be free of abnormality.	Troubles such as injury in patient's oral cavity and equipment failure may arise.	Control the water flow in accordance with page 16 to 17: "Description of operation and functions of components" described in the instruction manual. Contact your dealer or our office if recovery is not achieved.
11	Check motions of micromotor	Before start	micromotor rotation, water flow and so forth shall be free of abnormality.	Troubles such as injury in patient's oral cavity and equipment failure may arise.	Control the water flow in accordance with page 23: "Flow Adjustment" described in the instruction manual. Contact your dealer or our office if recovery is not achieved.
12	Check connection of handpiece	Before start	Leakage of water and air shall not be observed from handpiece connection.	Troubles such as injury in patient's oral cavity and equipment failure may arise.	Turn off the main switch and reattach the handpiece. Contact your dealer or our office if there is no improvement in symptoms after reattach handpiece.
13	Check of syringe operation	Before start	Water & air flow and condition of spray should be adequate.	Functions of syringe (drying, cooling & rinsing) may become less able.	Adjust the flow by following page: 23 "Adjustment of Parts" section of an operation manual. If you can't solve the problem by flow adjustment, contact authorized dealer or our office.
14	Vacuum handpiece	Before start	When pick up a handpiece, vacuum suppose to start. If slide knob is equipped with vacuum handpiece, by sliding a knob, vacuum line supposed to be opened / closed.	Vacuum function may become less able.	If you can't open / close vacuum line, follow the instructions page: 28 ~ 29 care & Maintenance section of operation manual. If you can't solve the problem after cleaning vacuum handpiece, contact your dealer or our office.
15	Saliva ejector handpiece	Before start	When pick up a handpiece, vacuum suppose to start. If slide knob is equipped with saliva ejector handpiece, by sliding a knob, vacuum line supposed to be opened / closed.	Vacuum function may become less able.	If you can't open / close vacuum line, follow the instructions page: 28 ~ 29 care & Maintenance section of operation manual. If you can't solve the problem after cleaning vacuum handpiece, contact your dealer or our office.
16	Cupfiller	Before start	Water is supplied through the cupfiller nozzle for certain time when cup filler switch is pressed.	Cup fill may not function properly. (no cup fill water, desired amount of water is not supplied)	Contact your dealer or our office if any abnormality arises.
17	Sensor Cupfiller (option)	Before start	When a paper cup is placed on the cupfiller, the cup shall be detected and cupfilling shall be executed. * Malfunction may arise if the cup is of another material grade (such as stainless steel and plastics) or if the paper cup is of dark color or pattern.	Cup fill may not function properly. (no cup fill water, desired amount of water is not supplied)	Contact your dealer or our office if any abnormality arises.
18	Bowl flush	Before start	Bowl flush supposed to function by pushing bowl flush button. For sensor cupfiller type, when a paper cup is placed on the cupfiller, bowl flush shall be executed.	Bowl flush may not function properly.	Contact your dealer or our office if any abnormality arises.
19	Water heater (option)	Before start	Turn on the water heater switch, the hot water comes out from cupfiller nozzle in a proper temperature.	Troubles such as injury in patient's oral cavity and equipment failure may arise.	Contact your dealer or our office if any abnormality arises.
20	Other	Before start	No abnormal noise or the like shall be produced from product's moving parts when the product is operated.	The product will not normally work and troubles may arise.	Contact your dealer or our office if any abnormality arises.
21	Check of air turbine bar	For each patient	Appropriate bar shall be positively mounted. Make sure to refer to the instruction manual attached to individual equipment.	The bar will not normally work and troubles may arise.	If abnormality such as flaw and deformation is found on the bar, replace the bar in accordance with the instruction manual attached to individual equipment.

MAINTENANCE AND INSPECTION

No.	Item	Frequency	Inspection method and diagnosis	Influence if inspection not conducted	Maintenance required in case of nonconformity
22	Check of scaler tip	For each patient	Appropriate tip shall be positively mounted and be correctly used. Make sure to refer to the instruction manual attached to the scaler.	The tip will not normally work and troubles may arise.	If the tip was worn or deformed, replace the tip in accordance with the instruction manual attached to the scaler. Contact your dealer or our office if any other trouble arises.
23	Care Exterior	After closing	Chemical, filthy water and so forth shall not be found (attached or remaining) on the product exterior.	Discoloration and deterioration to the exterior, and corrosion and rusting to metallic components may arise.	Execute wiping in accordance with "Method for care" described in the instruction manual.
24	Care Solid collector	After closing	Clean the filter of the solid collector.	Vacuum suction will become weak.	Clean the filter in accordance with "Method for care" described in the instruction manual.
25	Care Drain valve	Once every week	Water may enter the air line, and equipment failure may arise.	Drain the water from the air filter drain valve.	Drain the water from the air filter in accordance with "Method for care" described in the instruction manual.
26	Care Oil mist separator	Once every month	【Holder Type】 The oil level in the oil mist separator shall be lower than the red line.	Normal output will not be produced due to inferior handpiece exhaust.	Discharge the oil in accordance with "Method for care" described in the instruction manual.
			【ContinentalType】 Sponge of oil mist separator shall not saturate with oil.	Normal output will not be produced due to inferior handpiece exhaust.	Discharge the oil in accordance with "Method for care" described in the instruction manual.

Guide for Periodical Check-up

- Some parts and components of the products are degraded or deteriorated depending on the frequency of use. Annual check-up and maintenance, as well as replacement of consumable parts, are required.
- The required parts (including consumable parts) are listed below. It may be different from the following list depending on the option of the unit.
- For check-up and repair, call a technician of our authorized dealer.

Parts and components that require periodical check-up

No.	Parts Description	Standard Lifetime	No.	Parts Description	Standard Lifetime
1	Vacuum handpiece body	3 years	8	Regulator	3 years
2	Saliva ejector handpiece body	3 years	9	Valves	3 years
3	Foot controller	5 years	10	Switches	5 years
4	Water supply hose	3 years	11	Film viewer body part	5 years
5	Drain hose	3 years	12	Pressure gauge	3 years
6	Air supply hose	3 years	13	Arm section of moving part	7 years
7	Electric wiring of moving part	5 years	14	Control PCBs.	5 years

Consumable parts







No.	Parts Description	No.	Parts Description
1	Valve for vacuum handpiece body	5	Saliva ejector hose
2	Vacuum tip	6	Filter for oil mist separator
3	Handpiece tubings	7	Filter (Air & Water)
4	Vacuum hose	8	O-ring, Packing, Diaphragm

⚠ WARNING

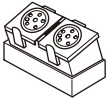
Execute the maintenance in accordance with this instruction manual and operating manual attached to each individual equipment (Dental light, Handpiece, etc..) .
Failure to maintain this product may lead to physical injury or property damage.

ACCESSORIES

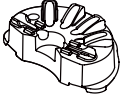
It may be different from the following list depending on the specification of the unit.

Accessories	intended use, etc.
Cotton containers 	The container to take in cotton and swab for dental treatment.
Waste receptacle 	Receptacle to do away with used cotton, etc.
Foot control handle 	Grip for portability of foot control to reduce hand contact.
Quick connector for water service outlet  Model number: MCL-04NH-1B	Quick connector that provides external equipment with water.
Quick connector for air service outlet  Model number: MC-04PH	Quick connector that provides external equipment with air.
Flushout tray 	The flushout tray holds the handpieces and allows the hands-free flushing.
Assistant sub tray 	Tray for placing vacuum tip or saliva ejector tip.
Curing light holder 	Holder for curing light.

DETACHABLE PARTS

PARTS	PARTS
Handpiece	Saliva ejector Handpiece
Handpiece hose	Vacuum tip
Drain cap	Solid collector lid
Basket strainer	Solid collector filter
Bowl flush nozzle	Male connector for water service outlet
Cupfiller nozzle	Male connector for air service outlet
Vacuum Handpiece	Oil mist separator

Declaration of Conformity

We hereby declare that the product listed below complies with the essential requirements of the Medical Device Directive: 93/42/EEC and RoHS Directive: 2011/65/EU based on category 8 of Annex I.

Product : DENTAL UNIT (CLASS IIa)

Model : CLESTA eIII " CLASS IIa " has been defined by the rule 9 of MDD Annex IX.

The product has been designed and manufactured in accordance with the European standards as the listed in the Declaration of Conformity.

Our full quality assurance system has been approved to MDD ANNEX II, excluding section 4 (Registration No. HD 60143723 0001) by Notified Body, TUV Rheinland LGA Products GmbH (NO.0197).

NOTE

EC REP

TAKARA COMPANY EUROPE GmbH

Berner Strasse 18, 60437

Frankfurt am Main, Germany

Tel: +49 69 506878 0

Fax: +49 69 506878 20

 **Belmont**



TAKARA BELMONT CORPORATION

2-1-1, Higashishinsaibashi, Chuo-ku, Osaka, 542-0083, Japan

TEL : +81 6 6213 5945

FAX : +81 6 6212 3680

www.takara-net.com